

■ GENERAL SPECIFICATIONS: TB 50

Working height (nominal) ..... 56 ft - 0 in (17.2 m)  
 Platform height (maximum) .... 50 ft - 5 in (15.4 m)  
 Platform reach (maximum) ..... 39 ft - 1 in (11.9 m)  
 Length  
 (booms down and retracted) ... 25 ft - 1.5 in (7.7 m)  
 Width..... 7 ft - 11.5 in (2.4 m)  
 Height  
 (booms down and retraced) ..... 7 ft - 9.5 in (2.4 m)  
 Wheelbase ..... 8 ft - 0 in (2.4 m)  
 Ground clearance..... 10 in (25 cm)  
 Weight (approximate)..... 12,550 lbs (5,693 kg)  
 Ground bearing strength ..... 64 psi (442 kPa)  
 Wheel loading, single, max. .... 6,525 lbs (2,960 kg)  
 Boom elevation ..... +75°/-18° to horizontal  
 Gradeability ..... 25%  
 Travel speeds:  
 booms down and retracted ... 3.0 mph (4.8 km/hr)  
 booms up and/or extended..... 1 mph (1.6 km/hr)  
 Turning radius, inside ..... 5 ft - 2 in (1.6 m)  
 Tires ..... 12 x 16.5 (30.5 x 42 cm), 10 ply  
 Electrical system ... 12 V dc (neg. chassis ground)  
 Environmental operating ranges:  
 ambient air temperature ..... 0°F to +110°F  
 ..... (-18°C to +43°C)  
 wind speed (maximum gust  
 or continuous) ..... 28 mph (45 km/hr)

Fuel tank capacity:  
 standard gasoline  
 or diesel ..... 20 gal USA (75.7 liters)  
 optional LPG ..... 43.5 lbs USA (20 kg)  
 Hydraulic oil tank capacity ..... 16 gal USA (60 liters)  
 Maximum hydraulic oil temperature  
 (at tank) ..... 200°F (93°C)  
 Hydraulic oil system  
 capacity ..... 25 gal USA (94.6 liters)  
 Hydraulic fluid recommended  
 Above 10°F (-13°C) Mobil DTE-13M (ISO VG32)  
 Below 10°F (-13°C) Mobil DTE-11M (ISO VG15)  
 Hydraulic system  
 maximum pressure ..... 2,500 psi (17,250 kPa)  
 Boom movement times  
 (complete range of movement):  
 Turntable Swing  
 CW or CCW (360°): ..... 100 - 110 seconds  
 Platform Rotation  
 CW or CCW (180°): ..... 16 - 20 seconds  
 Main Boom Elevation  
 UP:..... 40 - 45 seconds  
 DOWN: ..... 40 - 45 seconds  
 Boom Extension  
 OUT:..... 40 - 45 seconds  
 IN:..... 25 - 30 seconds

■ PLATFORM SPECIFICATIONS: TB 50

PLATFORM	SIZE inches (cm)	Unrestricted rated work load (total weight of personnel, tools, and materials that the platform is designed to carry above its floor -- same as UNRESTRICTED PLATFORM CAPACITY)
standard aluminum	30 x 60 (76 x 152)	Rated work load: 500 lbs (227 kg) Rated number of occupants: 2 people
optional aluminum	30 x 92 (76 x 233)	Rated work load: 450 lbs (204 kg) Rated number of occupants: 2 people

# SPECIFICATIONS

## OVERALL DIMENSIONS: TB 50

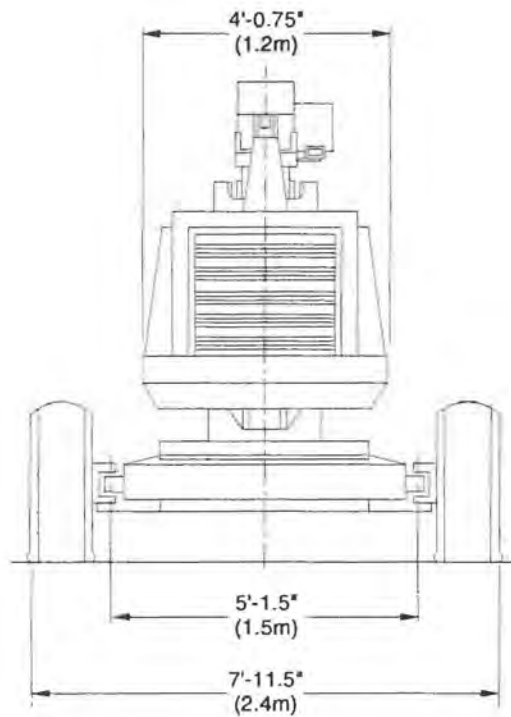
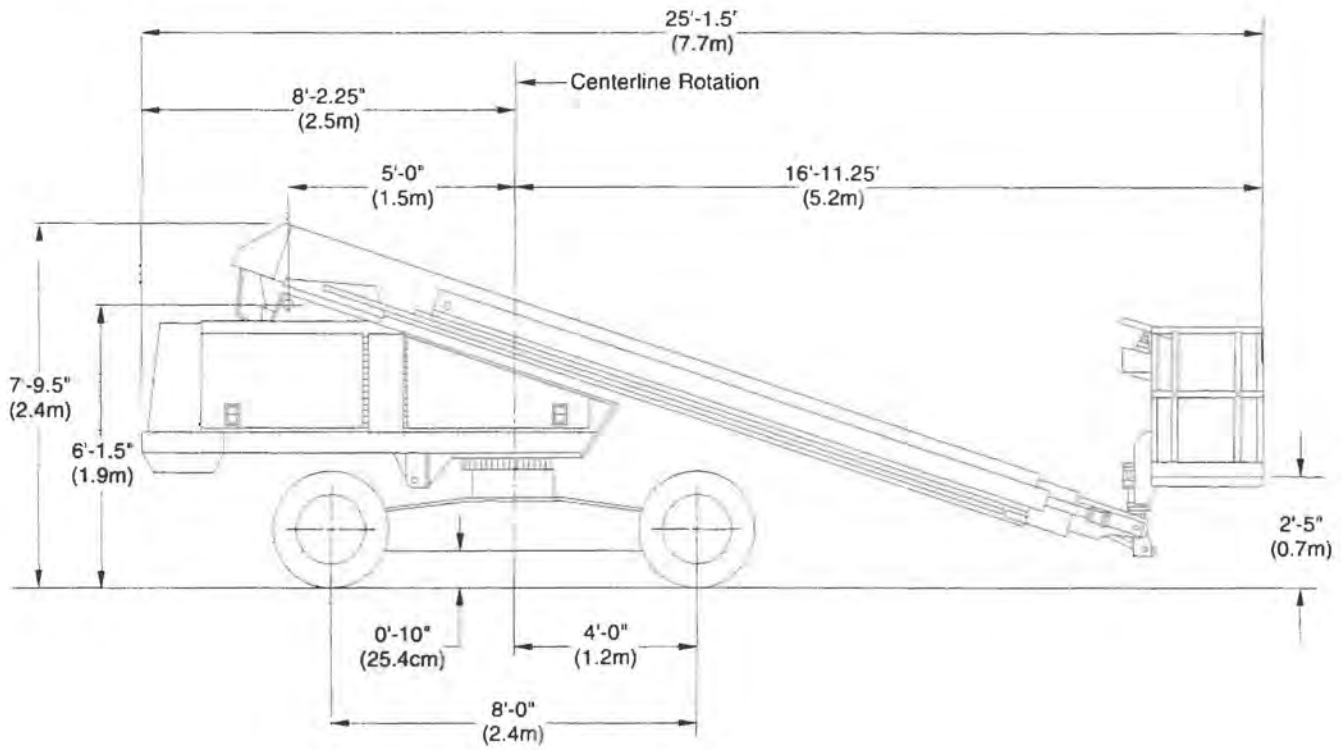

■ WORKING ENVELOPE: TB 50

