

snorkel

A38E



OPERATOR'S **MANUAL**

Part Number 8210052
August 2012

Serial number 004509 and after

DANGER

The aerial platform is not electrically insulated. Death or serious injury will result from contact with, or inadequate clearance from, an energized conductor.

Do not go closer than the minimum safe approach distance as defined by the Minimum Safe Approach Distance section in Chapter 3–Safety.

Regard all conductors as energized.

Allow for electrical wire sag and aerial platform sway.

If the platform, booms, or any part of the aerial platform contacts a high-voltage electrical conductor, the entire machine can become electrically charged.

If that happens, remain on the machine and do not contact any other structure or object. This includes the ground, adjacent buildings, poles, and any other objects that are not part of the aerial platform.

Such contact could make your body a conductor to the other object, creating an electrical shock hazard resulting in death or serious injury.

If an aerial platform is in contact with an energized conductor the platform operator must warn ground personnel in the vicinity to stay away. Their bodies can conduct electricity creating an electrical shock hazard resulting in death or serious injury.

Do not approach or leave the aerial platform until the electricity has been turned off.

Do not attempt to operate the lower controls when the platform, booms, or any part of the aerial platform is in contact with a high-voltage electrical conductor or if there is an immediate danger of such contact.

Personnel on or near an aerial platform must be continuously aware of electrical hazards, recognizing that death or serious injury can result from contact with an energized conductor.

California

Proposition 65 Warning

Battery posts, terminals, and related accessories contain lead and lead components, chemicals known to the State of California to cause cancer and birth defects or other reproductive harm. Wash hands after handling.

Table of Contents

Electrical Danger	Inside Front Cover
California Proposition 65	Inside Front Cover

Chapter 1 – Introduction

Aerial Platform Features	1
Options	1
Operator’s Manual	1
Safety Alerts	1
Operation	1
Maintenance	2
Manual of Responsibilities	2
Additional Information	2

Chapter 2 – Specifications

Component Identification	3
Working Envelope	4
General Specifications	5

Chapter 3 – Safety

Electrocution Hazards	7
Minimum Safe Approach Distance	7
Prestart Inspection	8
Work Place Inspection and Practices	8
Operation	8
Tip-Over and Falling Hazards	9
Electrical System	9
Hydraulic System	9
Placards and Decals	10

Chapter 4 – Safety Devices

Emergency Stop Controls	11
Upper Controls Emergency Stop Override	11
Emergency Lowering Knobs	11
Manual Turntable Rotation	12
Manual Tip Boom Retraction	12
Guardrails	12
Lanyard Anchors	13
Tilt Alarm	13
Horn	13
All Motion Alarm	13
Flashing Light	13

Chapter 5 – Gauges and Displays

Display Screen	15
Hour Meter	15
Battery Charge Indicator	15
Hydraulic Fluid Level Dipstick	15

Chapter 6 – Batteries

General Maintenance	17
Charging	17

Chapter 7 – Controls

Battery Disconnect	19
Lower Controls	19
Start Switch	19
Emergency Stop Button	19
Upper Controls Emergency Stop Override	20
Enable Button	20
Riser	20
Main Boom	20
Tip Boom	20
Turntable Rotation	20
Circuit Breaker Reset Button	20
Upper Controls	20
Emergency Stop Button	21
Joystick	21
Steer Switch	21
Drive/Steer Button	21
Riser Button	21
Main Boom Button	21
Tip Boom Button	21
Turntable Rotation Button	21
Platform Level Button	22
Horn	22
Platform Rotator	22

Chapter 8 – Prestart Inspection

Operator’s Manual Holder	23
Electrical System	23
Battery Fluid Level	23
Battery Terminals	24
Battery Charger	24
Battery Condition Indicator	24
Cables and Wiring Harness	25
Hydraulic System	25
Fluid Level	25
Fluid Filter	25
Hoses, Tubes, and Fittings	25
Tires and Wheels	26
Lower Control Station	26
Operating Controls	26
Lowering Alarm	26
Emergency Stop	26
Manual Turntable Rotation	27
Manual Tip Boom Retraction	27
Flashing Light	27
Structures	27
Weldments	28
Boom Slide Pads	28
Fasteners	28
Upper Control Station	28
Guardrail System	28
Lanyard Anchors	29
Operating Controls	29
Emergency Stop	29
Horn	30
Electrical Power Outlet	30
All Motion Alarm	30
Placards and Decals	30
Prestart Inspection Checklist	33

Table of Contents

Chapter 9 – Operation

Cold Weather Start-Up	35
Manually Warming the Hydraulic System.....	35
Preparing for Operation.....	35
Lower Controls	35
Upper Controls	36
Boom Operation	36
Driving and Steering.....	36
Drive Speeds.....	37
All Motion Alarm.....	37
Electrical Power Outlet	37

Chapter 10 – Stowing and Transporting

Stowing.....	39
Transporting	39
Driving	39
Winching	40
Hoisting	40
Securing for Transport.....	41

Chapter 11 – Emergency Operation

Emergency Lowering.....	43
Manual Turntable Rotation	43
Manual Tip Boom Retraction	43
Towing	44

Chapter 12 – Troubleshooting

Troubleshooting Chart.....	45
----------------------------	----

Appendix A – Glossary

Limited Warranty

Chapter 1 – Introduction

Aerial Platform Features

The aerial platform is a boom-supported elevating work platform used to raise personnel, their tools, and material to the workstation. The aerial platform has been designed for use on hard surface floors such as concrete. The booms are raised and lowered with hydraulic cylinders. Electric motors on the drive wheels provide power to move the aerial platform.

The standard machine includes the following features:

- Proportional drive and boom upper control
- Manual platform rotator
- Tie-down/lifting lugs
- Horn
- 5 degree tilt alarm
- All motion alarm
- Two wheel drive
- 362 degree non-continuous turntable rotation
- Zero tail swing
- 4 foot steel 475 lb capacity platform with gravity gate
- Solid non-marking tires
- 25 amp battery charger with charge indicator
- Five year limited warranty

The aerial platform has been manufactured, when applicable, to conform to all applicable requirements of the following organizations:

- Occupational Safety and Health Administration (OSHA)
- American National Standards Institute (ANSI)

Options

The following options may be provided on the machine:

- Flashing light
- AC 110V electrical outlet with GFCI at platform
- Special paint colors
- Environmental green oil
- Australian Standards (AS) certification
- Canadian Standards Association (CSA) certification

Operator's Manual

This manual provides information for safe and proper operation of the aerial platform. Some information in this manual refers to options that may or may not be on your machine. Read and understand the information in this Operator's Manual before operating the aerial platform on the job.

Additional copies of this manual may be ordered from Snorkel. Supply the model and manual part number from the front cover to assure that the correct manual will be supplied.

All information in this manual is based on the latest product information at the time of publication. Snorkel reserves the right to make product changes at any time without obligation.

Safety Alerts

A safety alert symbol is used throughout this manual to indicate danger, warning, and caution instructions. Follow these instructions to reduce the likelihood of personal injury and property damage. The terms danger, warning, and caution indicate varying degrees of personal injury or property damage that can result if the instruction is not followed.

Danger

Indicates an imminently hazardous situation which, if not avoided, will result in death or serious injury. This signal word is to be used in the most extreme situations.

Warning

Indicates a potentially hazardous situation which, if not avoided, could result in death or serious injury.

Caution

Indicates a potentially hazardous situation which, if not avoided, may result in minor or moderate injury. It may also be used to alert against unsafe practices.

Notes

Notes are used to provide special information or helpful hints to assist in aerial platform operation, but do not indicate a hazardous situation.

Operation

The aerial platform has built-in safety features and has been factory tested for compliance with Snorkel specifications and industry standards. However, any personnel lifting aerial platform can be potentially dangerous in the hands of untrained or careless operators.

Warning

The potential for an accident increases when the aerial platform is operated by personnel who are not trained and authorized. Death or serious injury could result from such accidents. Read and understand the information in this manual and on the placards and decals on the machine before operating the aerial platform on the job.

Training is essential and must be performed by a qualified person.

- Become proficient in knowledge and actual operation before using the aerial platform on the job.
- The operator must be trained and authorized to perform any functions of the aerial platform.
- Operation of the aerial platform must be within the scope of the machine specifications.

The operator bears ultimate responsibility for following all manufacturer's instructions and warnings, regulations and safety rules of their employer and/or any state or federal law.

Maintenance

Every person who maintains, inspects, tests, or repairs the aerial platform must be qualified to do so. Following the daily prestart inspection in this Operator's Manual will help keep the aerial platform in optimum working condition. Other maintenance functions must be performed by maintenance personnel who are qualified to work on the aerial platform.

Caution

Welding current can be very intense. Damage to electronic components may result. Connect the ground clamp as close as possible to the area being welded. Disconnect battery cables and any microprocessors and engine control modules before welding on the machine.

If it becomes necessary to weld aerial platform components as a method of repair, take all precautions to prevent damage to electronic circuitry and devices on the machine. This includes, but may not be limited to, disconnecting battery cables and electronic devices.

Do not modify this aerial platform without prior written consent of the Snorkel Engineering Department. Modification may void the warranty, adversely affect stability, or affect the operational characteristics of the aerial platform.

Manual of Responsibilities

All owners and users of the aerial platform must read, understand, and comply with all applicable regulations. Ultimate compliance to OSHA regulations is the responsibility of the user and their employer.

ANSI publications clearly identify the responsibilities of all personnel who may be involved with the aerial platform. A reprint of the "Manual of Responsibilities for Dealers, Owners, Users, Operators, Lessors and Lessees of ANSI/SIA A92.5-2006 Boom-Supported Elevating Work Platforms" is available from Snorkel dealers or from the factory upon request.

Copies are also available from:

Scaffold Industry Association, Inc.
P. O. Box 20574
Phoenix, AZ 85036-0574 USA

Additional Information

For additional information contact your local dealer or Snorkel at:

Snorkel International
P.O. Box 1160
St. Joseph, MO 64502-1160 USA
1-800-255-0317

<http://www.snorkellifts.com>

Chapter 2 – Specifications

Component Identification

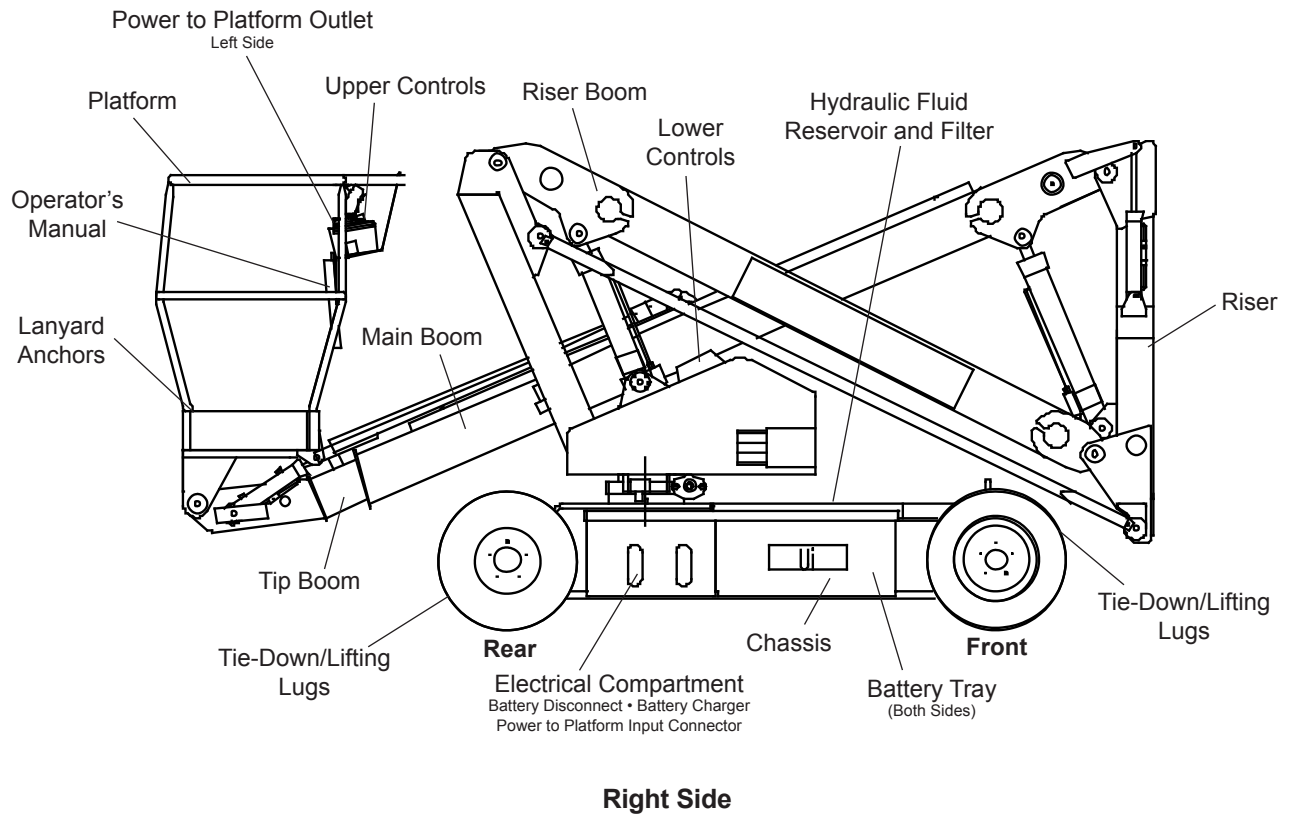

Working Envelope

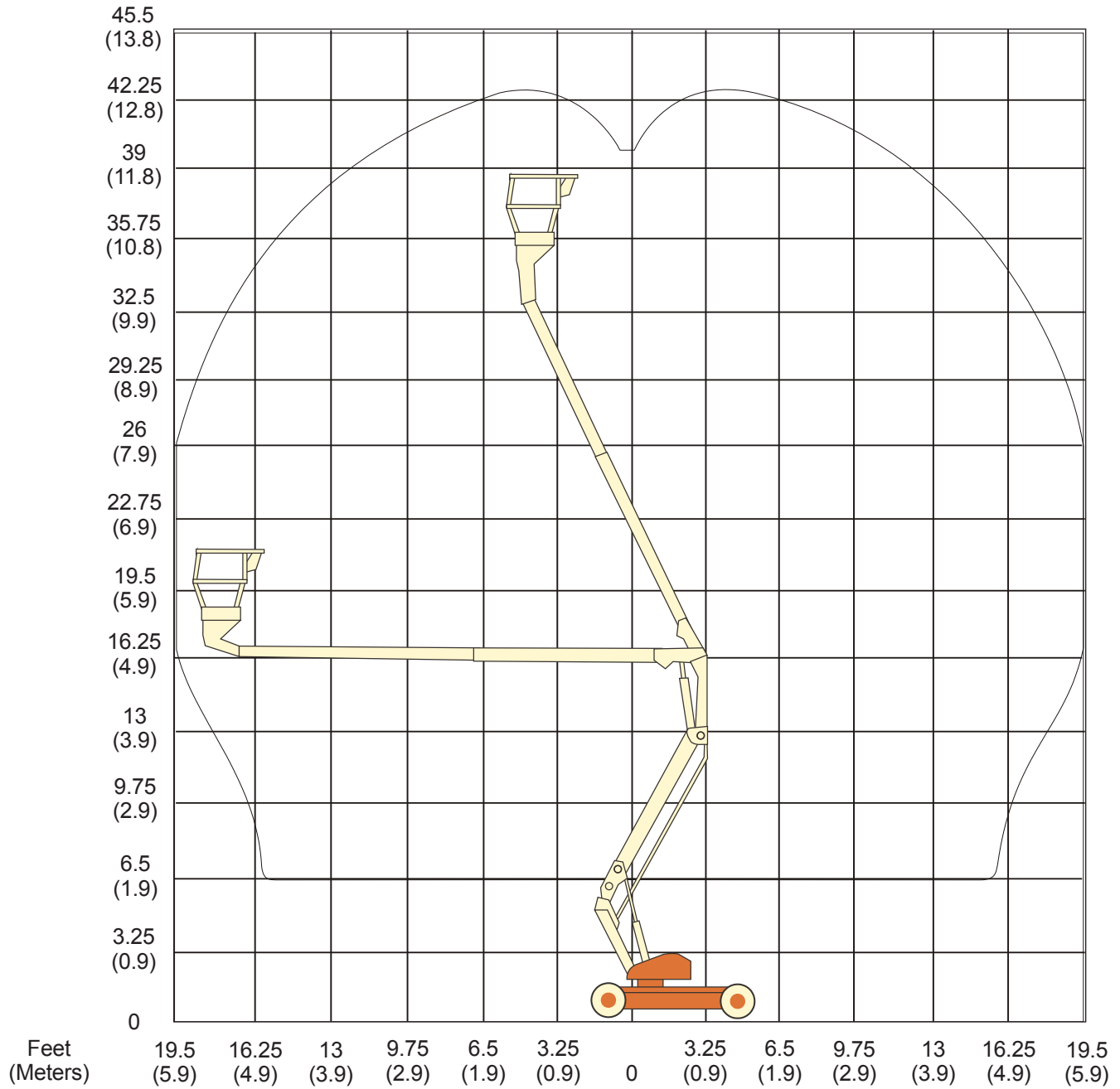

General Specifications

Aerial Platform

Working height	43' 7" (13.2 m)
Maximum platform height	37' 7" (11.4 m)
Up and over height	17' 9" (5.4 m)
Maximum horizontal reach	18' 4" (5.5 m)
Turntable rotation	362° non-continuous
Turning radius	
Inside	1' 4" (0.4 m)
Outside	7' 10" (2.4 m)
Wheelbase	4' 2" (1.27 m)
Ground clearance	5" (13 cm)
Weight, EVW	
Approximate	8,822 lbs (3,850 kg)
Width	4' 11" (1.5 m)
Stowed length	13' 3" (4.04 m)
Stowed height	6' 7" (2 m)

Platform

Dimensions, inside	1' 11" x 3' 4" (58.4 cm x 102 cm)
Toeboard height	6" (15.2 cm)
Rated work load	475 lb (215 kg)
Maximum number of occupants	2 people

Drive Speed

High, booms stowed	2.5 mph (4 km/h)
Low, booms raised/extended	0.45 mph (0.7 km/h)

Drive System

Standard	Two wheel drive
Gradeability	36%

Tires

Solid non-marking	22" x 9" x 16"
-------------------	----------------

Electrical System

Voltage	48 V DC
Source	Eight - 6 V 220 amp batteries
Fluid recommended	distilled water
Charger	25 amp

Hydraulic System

Maximum pressure	2,540 psi (17,513 kPa)
Reservoir capacity	6.5 US gal (24.6 l)
Maximum operating temperature	200°F (93°C)
Hydraulic fluid recommended	
Above 10°F (-12°C)	Mobil DTE-13M (ISO VG32)
Below 10°F (-12°C)	Mobil DTE-11M (ISO VG15)

Ambient Air Temperature Operating Range

Fahrenheit	0°F to 110°F
Celsius	-18°C to 43°C

Maximum Wind Speed

Gust or steady	28 mph (12.5 m/s)
----------------	-------------------

Chapter 3 – Safety

Knowledge of the information in this manual, and proper training, provide a basis for safely operating the aerial platform. Know the location of all controls and how they operate to act quickly and responsibly in an emergency.

Safety devices reduce the likelihood of an accident.

- Never disable, modify, or ignore any safety device.
- Safety alerts in this manual indicate situations where accidents may occur.

If any malfunction, hazard or potentially unsafe condition relating to capacity, intended use, or safe operation is suspected, stop aerial platform operation and seek assistance.

The operator bears ultimate responsibility for following all manufacturer's instructions and warnings, regulations and safety rules of their employer and/or any state or federal law.

Electrocution Hazards

The aerial platform is made of metal components and is not insulated. Regard all conductors as energized. Do not operate outside during a thunderstorm.

Minimum Safe Approach Distance

Minimum safe approach distances to energized power lines and their associated parts must be observed while operating the aerial platform.

▲Danger

The aerial platform is not electrically insulated. Death or serious injury will result from contact with, or inadequate clearance from, an energized conductor. Do not go closer than the minimum safe approach distance as defined by ANSI.

ANSI publications define minimum distances that must be observed when working near bus bars and energized power lines. Table 1 and Figure 3 are reprinted courtesy of Scaffold Industry Association, ANSI/SIA A92.5.

Voltage Range (Phase to Phase)	Minimum Safe Approach Distance	
	Feet	Meters
0 to 300V	Avoid Contact	
Over 300V to 50kV	10	3.05
Over 50kV to 200kV	15	4.60
Over 200kV to 350kV	20	6.10
Over 350kV to 500kV	25	7.62
Over 500kV to 750kV	35	10.67
Over 750kV to 1000kV	45	13.72

Table 1 – Minimum Safe Approach Distance

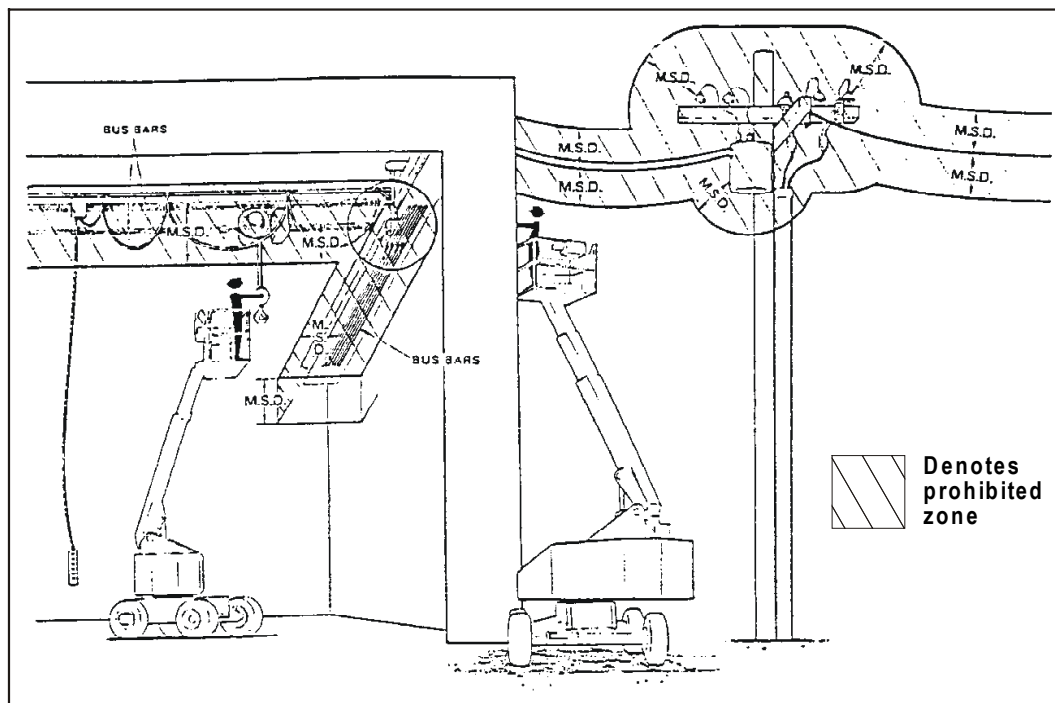

Figure 3 – Minimum Safe Approach Distance

Prestart Inspection

Perform a prestart inspection before each shift as described in Chapter 8. Do not use the aerial platform on the job unless you are trained and authorized to do so.

Work Place Inspection and Practices

Do not use the aerial platform as a ground connection when welding.

- The welding ground clamp must be attached to the same structure that is being welded.
- Electrical current flow can be very intense, causing serious internal damage to some components.

Inspect the area before and during aerial platform use. The following are some potential hazards that may be in the work place:

- Debris
- Slopes
- Drop-offs or holes
- Bumps and floor obstructions
- Overhead obstructions
- Unauthorized persons
- High voltage conductors
- Wind and weather conditions
- Inadequate surface and support to withstand load forces applied by the aerial platform in all operating configurations

Before using the aerial platform in any hazardous (classified) location, make certain it is approved and of the type required by ANSI/NFPA 505 for use in that particular location.

Know and understand the job site traffic-flow patterns and obey the flagmen, road signs, and signals.

While operating the aerial platform, a good safety practice is to have qualified personnel in the immediate work area to:

- Help in case of an emergency
- Operate emergency controls as required
- Watch for loss of control by platform operator
- Warn the operator of any obstructions or hazards that may not be obvious to them
- Watch for soft terrain, sloping surfaces, drop-offs, etc. where stability could be jeopardized
- Watch for bystanders and never allow anyone to be under, or to reach through the booms while operating the aerial platform

Danger

Pinch points may exist between moving components. Death or serious injury will result from becoming trapped between components, buildings, structures, or other obstacles. Make sure there is sufficient clearance around the machine before moving the chassis, booms, or platform. Allow sufficient room and time to stop movement to avoid contact with structures or other hazards.

Always look in the direction of movement.

- Drive with care and at speeds compatible with the work place conditions.
- Use caution when driving over rough ground, on slopes, and when turning.
- Do not engage in any form of horseplay or permit riders any place other than in the platform.

Secure all accessories, containers, tools, and other materials in the platform to prevent them from accidentally falling or being kicked off the platform. Remove all objects that do not belong in or on the aerial platform.

Never steady the platform by positioning it against another platform.

Warning

The potential for an accident increases when operating an aerial platform that is damaged or malfunctioning. Death or serious injury could result from such accidents. Do not operate the aerial platform if it is damaged or malfunctioning.

Do not operate the aerial platform if it is damaged or not functioning properly. Qualified maintenance personnel must correct the problem before putting the aerial platform back into service.

Operation

Use three points of support when entering or exiting the platform. For example, use two hands and one foot when climbing into the platform.

Never cover the platform floor grating or otherwise obstruct your view below. Make sure the area below the platform is free of personnel before lowering.

Keep both feet positioned firmly on the platform floor.

- Operate the controls slowly and deliberately to avoid jerky and erratic operation.
- Always stop the controls in neutral before going in the opposite direction.

Do not dismount while the aerial platform is in motion or jump off the platform.

Properly stow the aerial platform and secure it against unauthorized operation at the end of each work day, before transporting, or if it is left unattended.

Tip-Over and Falling Hazards

Operate the aerial platform only on a firm, flat, level surface capable of withstanding all load forces imposed by the aerial platform in all operating conditions. Refer to the General Specifications chart for the maximum wheel load and ground pressure. Raise the booms only when the aerial platform is on level ground.

Danger

The aerial platform can tip over if it becomes unstable. Death or serious injury will result from a tip-over accident. Do not drive or position the aerial platform for elevated use near any drop-off, hole, slope, soft or uneven ground, or other tip-over hazard. Do not raise the platform outdoors in wind speeds above 28 mph (12.5 m/s).

All platform occupants must wear a fall restraint device connected to a lanyard anchor point.

It is best not to transfer from the platform to another structure or from the structure to the platform, unless that is the safest way to do the job. Judge each situation separately taking the work environment into account. If it is necessary to transfer from the platform to another structure the following guidelines apply:

1. Where possible, place the platform over a roof or walking structure to do the transfer.
2. Transfer your anchorage from one structure to the other before stepping across.
3. Remember that you might be transferring to a structure where *personal fall arrest* is required.
4. Use the platform entrance, do not climb over or through the guardrails.

Do not operate the aerial platform in windy or gusty conditions. Do not add anything to the aerial platform that will increase the wind loading such as billboards, banners, flags, etc.

Never operate the aerial platform without all parts of the guardrail system in place and the gate closed. Make sure that all protective guards, cowlings, and doors are securely fastened.

Do not exceed the platform capacity as indicated on the platform rating placard on the platform. Do not carry loads that extend beyond the platform guardrails without prior written consent from Snorkel.

Do not operate the aerial platform from trucks, trailers, railway cars, floating vessels, scaffolds, or similar equipment unless the application is approved in writing by Snorkel.

Do not use the aerial platform as a crane, hoist, jack, or for any purpose other than to position personnel, tools, and materials.

Do not climb on the guardrails or use ladders, planks, or other devices to extend or increase the work position from the platform.

Take care to prevent rope, electrical cords, and hoses, etc., from becoming caught in or on the aerial platform.

- If the platform or booms becomes caught on an adjacent structure or other obstacle and is prevented from normal motion, reverse the control to free the platform.
- If control reversal does not free the platform, evacuate the platform before attempting to free it.

Electrical System

Charge the batteries in a well-ventilated area free of flame, sparks, or other hazards that might cause fire or explosion.

Do not operate any of the aerial platform functions while the battery charger is plugged in.

Warning

Batteries give off hydrogen and oxygen that can combine explosively. Death or serious injury could result from a chemical explosion. Do not smoke or permit open flames or sparks when checking the batteries.

Battery acid can damage the skin and eyes. Serious infection or reaction could result if medical treatment is not given immediately. Wear face and eye protection when working near the batteries.

- Batteries contain sulfuric acid that could damage your eyes or skin on contact.
- Wear a face shield, rubber gloves, and protective clothing when working around batteries.
- If acid contacts your eyes, flush immediately with clear water and get medical attention.
- If acid contacts your skin, wash off immediately with clear water.

Hydraulic System

The hydraulic system contains hoses with hydraulic fluid under pressure.

⚠ Danger

Hydraulic fluid escaping under pressure can have enough force to inject fluid into the flesh. Serious infection or reaction will result if medical treatment is not given immediately. In case of injury by escaping hydraulic fluid, seek medical attention at once.

Do not place your hand or any part of your body in front of escaping hydraulic fluid. Use a piece of cardboard or wood to search for hydraulic leaks.

Placards and Decals

The aerial platform is equipped with placards and decals that provide instruction for operation and accident prevention. Do not operate the aerial platform if any placards or decals are missing or not legible.

Chapter 4 – Safety Devices

This aerial work platform is manufactured with safety devices, placards, and decals to reduce the likelihood of an accident.

- For the safety of all personnel, do not disable, modify, or ignore any safety device.
- Safety devices are included in the daily prestart inspection.

⚠Warning

The potential for an accident increases when safety devices do not function properly. Death or serious injury could result from such accidents. Do not alter, disable, or override any safety device.

If any safety devices are defective, remove the aerial platform from service until qualified maintenance personnel can make repairs.

Emergency Stop Controls

There is an emergency stop control at the lower and upper controls. Both the lower and upper control emergency stop buttons must be on to operate the machine.

At the lower controls, the emergency stop is a two-position push button (refer to Figure 4.1).

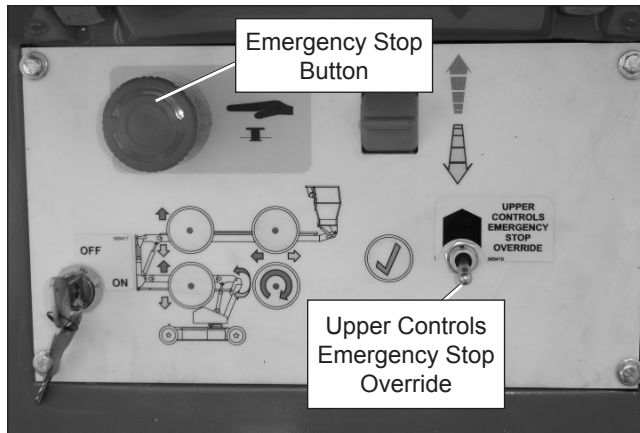

Figure 4.1 – Lower Controls

- Push the emergency stop button inward to disconnect power to all control circuits.
- Twist the button clockwise to restore power.

At the upper controls, the emergency stop is a two-position push button (refer to Figure 4.2).

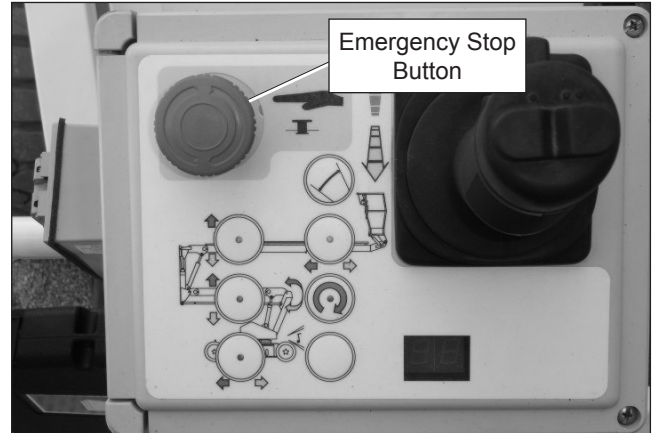

Figure 4.2 – Upper Controls

- Push the emergency stop button inward to disconnect power to the upper control circuits.
- Twist the button clockwise to restore power.

Upper Controls Emergency Stop Override

The upper controls emergency stop override (refer to Figure 4.1) allows the platform to be lowered from the lower controls in the event the upper controls emergency stop button is depressed.

- Hold the upper controls emergency stop override switch upward to enable the lower controls.

Emergency Lowering Knobs

The emergency lowering knobs may be used to lower the booms if there is a malfunction in the hydraulic or electrical system.

A knob is located on the base end of the riser boom cylinder and on the base end of the main boom lift cylinder (refer to Figure 4.3).

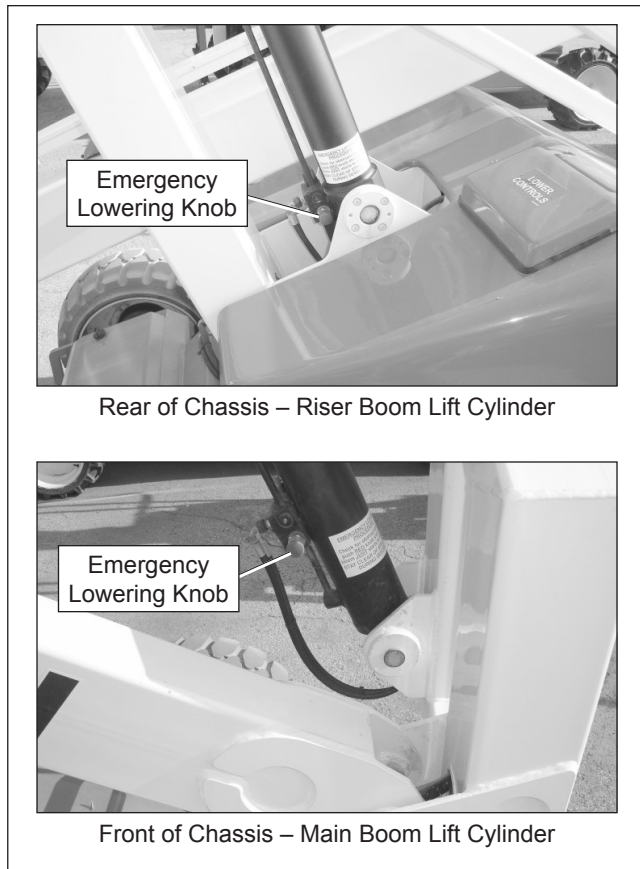

Figure 4.3 – Emergency Lowering Knobs

- Push the emergency lowering knob inward to open the cylinder bleed down valve for emergency lowering.

Manual Turntable Rotation

The rotation drive output shaft may be used to manually rotate the turntable if there is a malfunction in the hydraulic or electrical system.

The output shaft is on the end of the rotation worm drive below the turntable (refer to Figure 4.4).

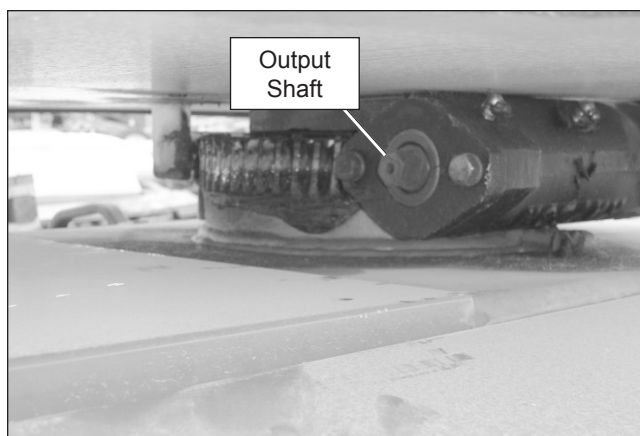

Figure 4.4 – Rotation Worm Drive

Manual Tip Boom Retraction

The manual hand pump may be used to manually retract the tip boom if there is a malfunction in the hydraulic or electrical system.

The hand pump is on the control valve underneath the front chassis cover (refer to Figure 4.5).

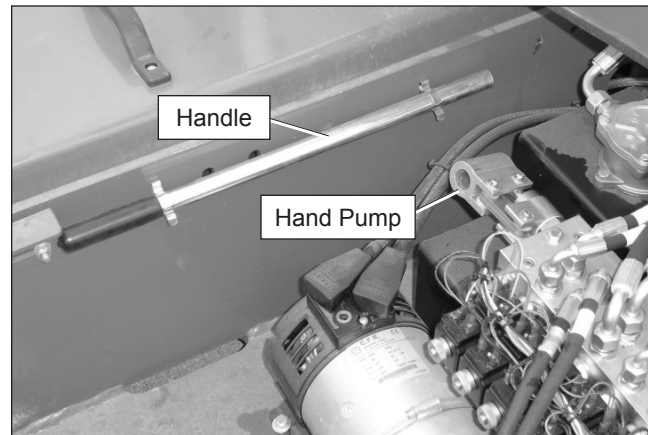

Figure 4.5 – Control Valve Under Front Chassis Cover

Guardrails

The guardrails (refer to Figure 4.6) help protect personnel from falling off the platform.

The guardrail system includes:

- A top rail
- A mid rail
- A gravity gate
- Toeboards around the sides of the platform

The gravity gate allows for access to the platform and closes automatically after entering or exiting the platform. After entering the platform check to make sure the gate is fully lowered and even with the mid rail.

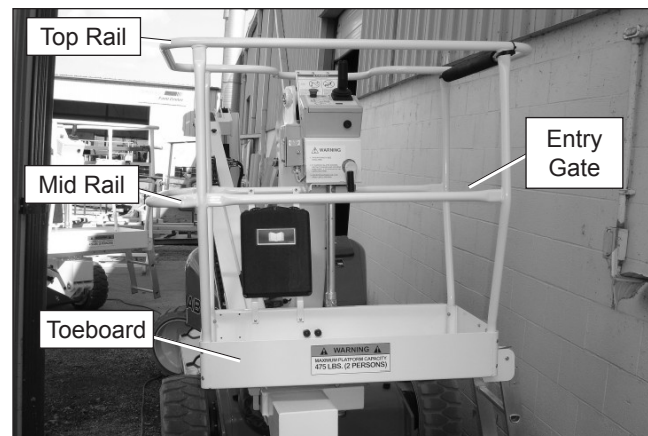

Figure 4.6 – Platform

Lanyard Anchors

Two lanyard anchors for fall restraint anchorage are provided at the rear of the platform (refer to Figure 4.7).

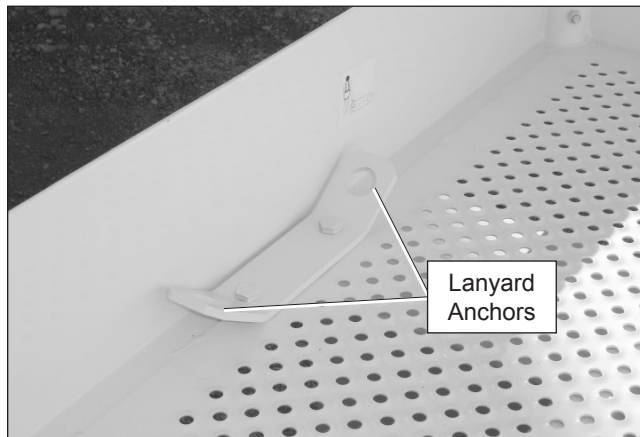

Figure 4.7 – Inside Rear of Platform

Note

The lanyard anchors are not for lifting or tying the machine down.

- All personnel in the platform must connect their fall restraint device to a lanyard anchor before raising the platform.
- Attach only one fall restraint device to each lanyard anchor.
- Do not use the aerial platform for personal fall arrest anchorage.

Tilt Alarm

If the aerial platform chassis is out of level more than five degrees when the main boom is raised or extended, or when the riser boom is raised, an alarm will sound. The tilt alarm is located under the upper control panel.

▲Danger

The aerial platform can tip over if it becomes unstable. Death or serious injury will result from a tip-over accident. Do not drive or position the aerial platform for elevated use near any drop-off, hole, slope, soft or uneven ground, or other tip-over hazard.

Completely lower the booms and then drive to a level surface when the tilt alarm sounds.

The tilt alarm is for added protection and does not justify operating on anything other than firm, flat, level surfaces.

Horn

The horn may be used to warn personnel on the ground. The horn switch is to the right of the emergency stop button on the upper control panel (refer to Figure 4.8). The horn is operational when the machine is set up for operation from the upper controls.

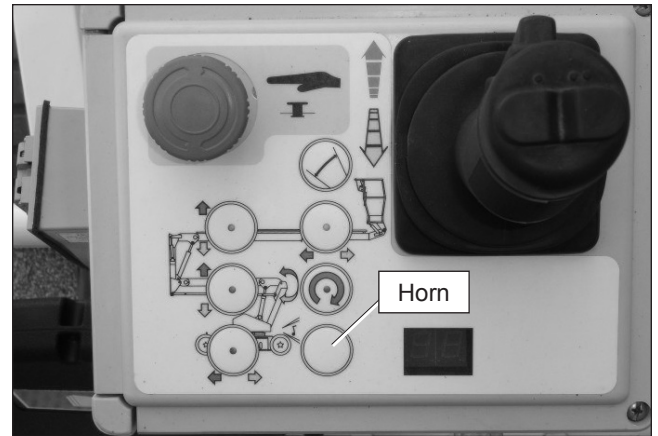

Figure 4.8 – Upper Controls

All Motion Alarm

The all motion alarm sounds, in short beeps, anytime the machine functions are being operated. The alarm is used to warn personnel in the work area to stand clear.

Flashing Light

An amber flashing light may be located on the top of the turntable. The flashing light warns personnel that the aerial platform is in the area.

The light flashes at approximately one flash per second when the machine is set up for operation at the lower controls.

Chapter 5 – Gauges and Displays

The aerial platform is equipped with an hour meter and a battery charge indicator to monitor the condition of the machine before and during operation.

Display Screen

An LED display screen is located on the upper control panel (refer to Figure 5.1).

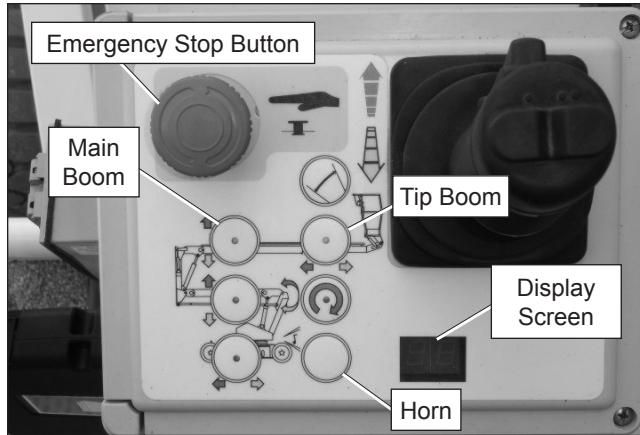

Figure 5.1 – Upper Controls

The display screen shows:

- general operators information.
- fault codes used to locate and eliminate situations where machine operation may be interrupted.

Note

Refer to Chapter 12 for a list of fault codes.

Hour Meter

The hour meter is part of the digital display on the upper control panel (refer to Figure 5.1). It measures the accumulated aerial platform operating time.

To view the hour meter reading:

1. From the lower controls, twist the emergency stop button clockwise to the on position and turn the start switch on.
2. From the upper controls, push the emergency stop button inward.
3. Press and hold the horn and main boom buttons while twisting the emergency stop button to restore power. The display should now have “hr” shown.
4. Press the right side of the steer switch to scroll through the hour meter reading, two digits at a time.

For example, if pressing the switch slowly three times displays “10” followed by “40” and then “hr” after the third time, the accumulated aerial platform operating time is 1,040 hours.

5. Push the emergency stop button inward.

Battery Charge Indicator

The battery charge indicator is on the battery charger on the right side of the chassis (refer to Figure 5.2). When the batteries are charging, the battery charge indicator displays the level of charge in the batteries.

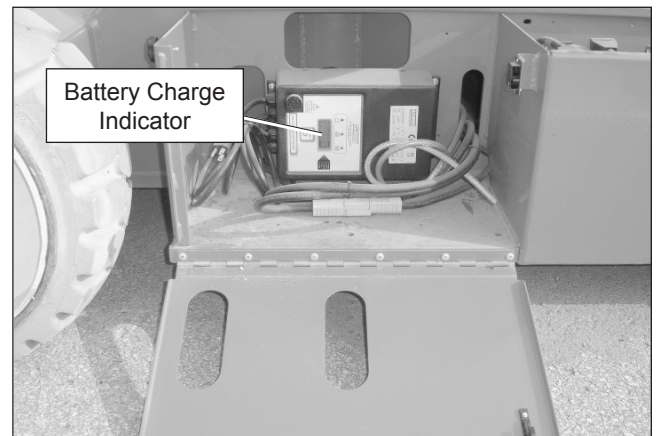

Figure 5.2 – Right Side of Chassis

Hydraulic Fluid Level Dipstick

The dipstick on the reservoir fill cap indicates the proper level of hydraulic fluid in the reservoir. The reservoir is inside the front of the chassis (refer to Figure 5.3).

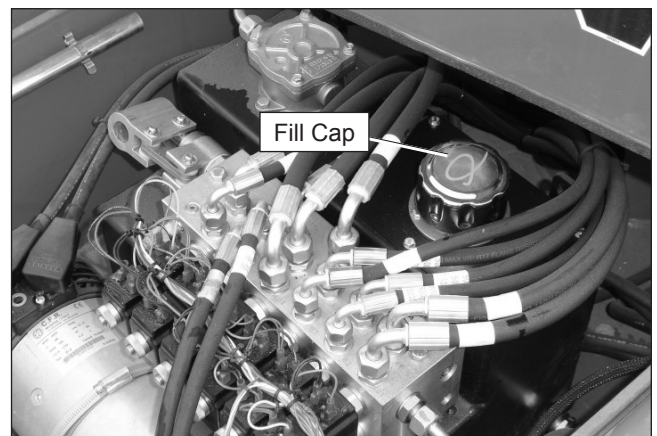

Figure 5.3 – Inside Front of Chassis

Remove the chassis cover and check the fluid level with the aerial platform in the stowed position. Otherwise, the cylinders act as a large reservoir for hydraulic fluid making the level appear too low. The fluid should be visible on the dipstick.

Chapter 6 – Batteries

The battery trays, located on each side of the chassis, contain eight, 220 amp, 6 volt batteries to operate the aerial platform drive and control systems.

To access the batteries, loosen the knob on each side of the tray and remove the cover.

For optimal battery performance the battery fluid level must be maintained and the battery connections must be kept clean.

General Maintenance

Always keep the batteries clean, free of dirt and corrosion. A film on top of the battery can accelerate discharge.

Warning

Battery acid can damage the skin and eyes. Serious infection or reaction could result if medical treatment is not given immediately. Wear face and eye protection when working near the batteries.

If necessary, clean the batteries, terminals, and cable ends (refer to Figure 6.1) with a wire brush or terminal cleaning tool.

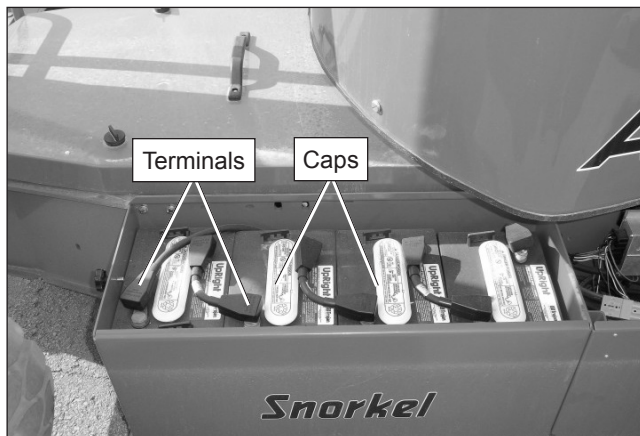

Figure 6.1 – Battery Tray

Use distilled water to refill the batteries. Avoid water containing metallic solids such as iron which can reduce the life of the batteries.

Consult a battery charger specialist if extreme temperature use is unavoidable.

- Cold reduces battery capacity and retards charging.
- Heat increases water usage and can result in overcharging.
- Very high temperatures can cause thermal run away which may lead to an explosion or fire.

Charging

The aerial platform is equipped with a 25 amp battery charger. The battery charger is located in the electrical compartment on the right side of the chassis.

Warning

Batteries give off hydrogen and oxygen that can combine explosively. Death or serious injury can result from a chemical explosion. Charge the batteries only in a well ventilated area away from sparks or flame.

Caution

The batteries may be overcharged and/or damaged if the charger is plugged in after the charge cycle is complete. Do not leave the battery charger on for more than 48 hours.

It may take from 1½ to 16 hours to recharge the batteries depending on the amount of discharge. If the charging cycle exceeds 16 hours without the batteries being fully recharged, unplug the charger and have the batteries checked.

Fully recharge the batteries, immediately after use.

- One charging cycle per day is preferred.
- Fully charged batteries perform best.
- The deeper the discharge, the fewer number of cycles a battery will deliver. Deep discharges deteriorate the battery quicker than light shallow cycles.
- An overly discharged battery may need to be cycled a few times before it can fully recover.
- If a battery begins to heat before becoming fully charged, it may be necessary to recharge and discharge the battery a few times.

Use the following procedure to charge the batteries.

1. Make sure the battery disconnect inside the electrical compartment is plugged in (refer to Figure 6.2).

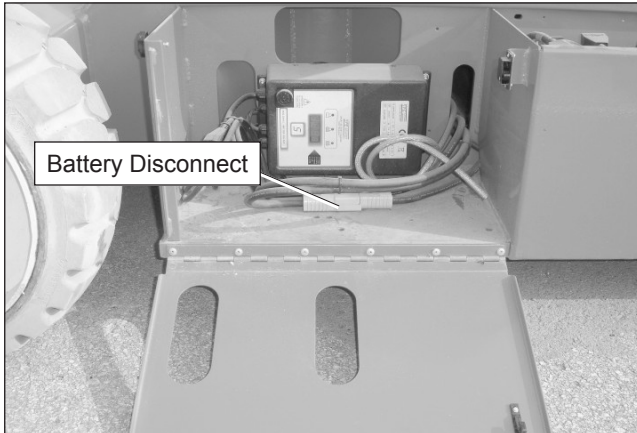

Figure 6.2 – Electrical Compartment

2. Remove the cover on each side of the chassis to access the batteries. Remove the caps from each battery (refer to Figure 6.1).
3. Visually check the battery fluid level making sure the level is 3/8" (10 mm) above the plates. If needed, add distilled water.
4. Tightly replace the caps on each battery and replace and latch the battery tray covers.
5. Plug the battery charger into a properly grounded outlet (115 volt AC, 60 Hz) using a 3 conductor, 12 gauge (1.5 mm) or larger extension cord. The outlet must be equipped with GFCI protection. The extension cord must be as short as possible and in good electrical condition.

Note

Do not operate any of the aerial platform functions while the battery charger is plugged in.

6. Visually inspect the battery charge indicator (refer to Figure 6.2).
 - The charger will turn on three to five seconds after a complete electrical connection is made.
 - The LED charge indicator will be lit while the batteries are charging.
 - When the batteries are fully charged, the charge indicator will blink.

⚠ Caution

The batteries may be overcharged and/or damaged if the charger is plugged in after the charge cycle is complete. Do not leave the battery charger on for more than 48 hours.

7. After the charge cycle is complete, unplug the extension cord from the battery charger and allow the batteries to cool.
8. Remove the cover on each side of the chassis to access the batteries. Remove the caps from each battery (refer to Figure 6.1).
9. Visually check the battery fluid level making sure the level is 3/8" (10 mm) above the plates. If needed, add distilled water.
10. Tightly replace the caps on each battery and replace and latch the battery tray covers.

Chapter 7 – Controls

⚠ Danger

Pinch points may exist between moving components. Death or serious injury will result from becoming trapped between components, buildings, structures, or other obstacles. Make sure all personnel stand clear while operating the aerial platform.

- Controls to position the platform are located on the lower control panel on the turntable and on the upper control panel in the platform.
- Controls to drive the aerial platform are located on the upper control panel only.

Battery Disconnect

The battery disconnect is located inside the electrical compartment (refer to Figure 7.1).

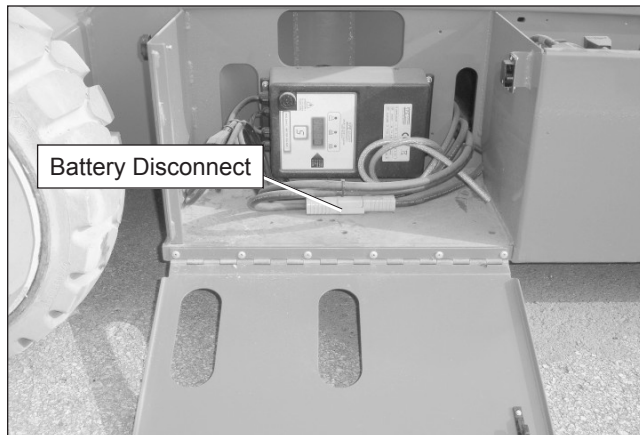

Figure 7.1 – Battery Disconnect

The battery disconnect removes electrical power from all electrically controlled functions when in the off position.

- Make sure the battery disconnect inside the electrical compartment is plugged in to electrically connect the batteries to the electrical system.

⚠ Caution

Only authorized personnel should operate the aerial platform. Unqualified personnel may cause injury to coworkers or property damage. Unplug the battery disconnect before leaving the aerial platform unattended.

- Unplug the battery disconnect to prevent unauthorized use of the aerial platform.

Lower Controls

The lower controls (refer to Figure 7.2) are located on the left side of the turntable. Boom and platform functions can be operated from the lower controls.

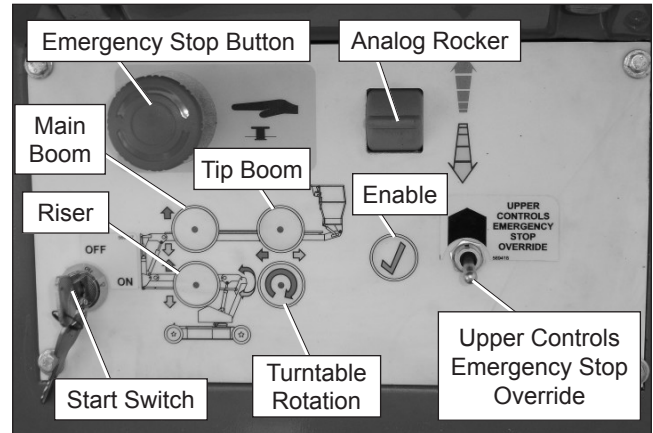

Figure 7.2 – Lower Controls

The following are located on the lower control panel:

- Start switch
- Emergency stop button
- Upper controls emergency stop override
- Enable
- Analog rocker
- Riser select
- Main boom select
- Tip boom select
- Turntable rotation select

Start Switch

The start switch (refer to Figure 7.2) connects power to all control circuits with a key switch.

- Turn the switch to the on position to connect the electrical power to the lower and upper controls.
- When the machine is not in use, turn the switch to the off position to preserve the battery charge.

Emergency Stop Button

The emergency stop (refer to Figure 7.2) is a two-position red push button.

- Push the emergency stop button inward to disconnect power to all control circuits.
- Twist the emergency stop button clockwise to restore power.

Both the lower and upper control emergency stop buttons must be on to operate the machine.

Upper Controls Emergency Stop Override

The platform can be lowered in an emergency from the lower controls using the upper controls emergency stop override (refer to Figure 7.2).

- Hold the upper controls emergency stop override switch upward to enable the lower controls.

Enable Button

The enable button (refer to Figure 7.2) must be pressed when operating the turntable, riser, and main boom functions with the analog rocker from the lower controls.

Analog Rocker

The analog rocker (refer to Figure 7.2) is used to operate the selected boom or turntable function. The rocker switch is spring returned to the center off position.

- Push the switch forward in the direction of the red arrow to operate the selected function in the direction of the red arrow associated with that function.
- Pull the switch backward in the direction of the yellow arrow to operate the selected function in the direction of the yellow arrow associated with that function.

Riser

The riser button (refer to Figure 7.2) is used to select the riser boom function. The light in the center of the button will illuminate when the riser boom is selected.

Main Boom

The main boom button (refer to Figure 7.2) is used to select the main boom function. The light in the center of the button will illuminate when the main boom is selected.

Tip Boom

The tip boom button (refer to Figure 7.2) is used to select the tip boom function. The light in the center of the button will illuminate when the tip boom is selected.

Turntable Rotation

The turntable rotation button (refer to Figure 7.2) is used to select the turntable rotation function. The light in the center of the button will illuminate when turntable rotation is selected.

Circuit Breaker Reset Button

The electrical power outlet at the platform has a 15 amp circuit breaker. The reset button is on the right side of the electrical box (refer to Figure 7.3).

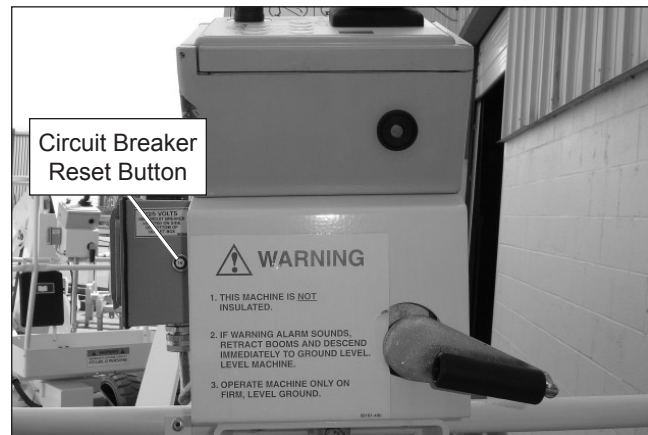

Figure 7.3 – Electrical Power Outlet

The circuit breaker protects the electrical wiring and components from electrical overload in case of a short circuit or other fault.

Caution

A tripped circuit breaker indicates a malfunction in the electrical system. Component damage may result if the cause of the malfunction is not corrected. Do not operate the electrical power outlet if the circuit breaker trips repeatedly.

Push the button to reset the circuit breaker.

Upper Controls

The upper controls (refer to Figure 7.4) are located on the control panel at the platform. Boom, platform, and drive functions can be operated from the upper controls.

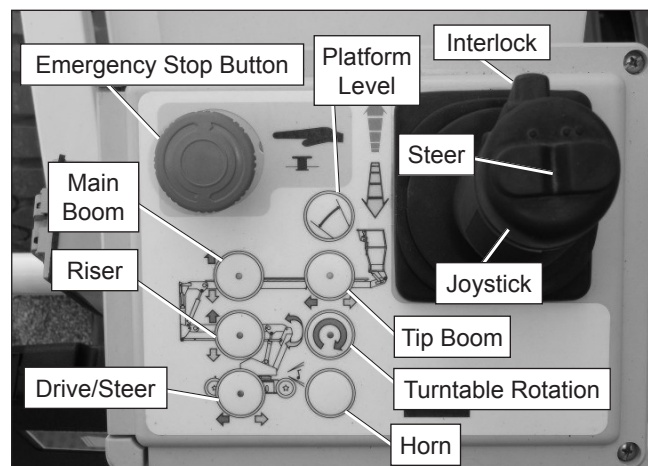

Figure 7.4 – Upper Controls

The following controls are located on the upper control panel:

- Emergency stop button
- Joystick
- Steer switch
- Drive/steer select
- Riser select
- Main boom select
- Tip boom select
- Turntable rotation select
- Platform level select
- Horn button
- Platform rotator

Emergency Stop Button

The emergency stop (refer to Figure 7.4) is a two-position red push button.

- Push the emergency stop button inward to disconnect power to the upper controls.
- Twist the emergency stop button clockwise to restore power.
- Push the emergency stop button inward when the upper controls are not in use to protect against unintentional operation.

Both the lower and upper control emergency stop buttons must be on to operate the machine.

Joystick

The joystick (refer to Figure 7.4) is used to either drive the aerial platform or to operate the boom and turntable after selecting the appropriate function.

- Press the drive/steer button to use the joystick to drive the aerial platform.
- Press the boom or turntable buttons to use the joystick to operate those functions.

Movement of the joystick in a given direction produces a corresponding movement of the aerial platform as indicated on the upper control placard. The steering and drive functions may be operated separately or simultaneously.

Steer Switch

The steer switch (refer to Figure 7.4) is a momentary contact, rocker switch on top of the drive joystick. This switch controls the two front wheels to steer the aerial platform. The

- To steer to the right, engage the interlock switch on the joystick and hold down the right side of the steer switch.
- To steer to the left, engage the interlock switch on the joystick and hold down the left side of the steer switch.

Note

The steering wheels are not self-centering. Set the steering wheels straight ahead after completing a turn.

Drive/Steer Button

The drive/steer button (refer to Figure 7.4) is used with the joystick to drive and steer the aerial platform.

- To drive forward press the drive/steer button and then push the joystick forward, the direction of the red arrow.
- To drive in reverse press the platform raise/lower button and then pull the joystick backward, the direction of the yellow arrow.

Note

The platform will not raise or lower while driving.

Riser Button

The riser button (refer to Figure 7.4) is used with the joystick to raise and lower the riser boom.

- To raise the riser boom, press the riser button and then push the joystick forward, the direction of the red arrow.
- To lower the riser boom, press the riser button and then pull the joystick backward, the direction of the yellow arrow.

Main Boom Button

The main boom button (refer to Figure 7.4) is used with the joystick to raise and lower the main boom.

- To raise the main boom, press the main boom button and then push the joystick forward, the direction of the red arrow.
- To lower the main boom, press the main boom button and then pull the joystick backward, the direction of the yellow arrow.

Tip Boom Button

The tip boom button (refer to Figure 7.4) is used with the joystick to extend and retract the tip boom.

- To extend the tip boom, press the tip boom button and then push the joystick forward, the direction of the red arrow.
- To retract the tip boom, press the tip boom button and then pull the joystick backward, the direction of the yellow arrow.

Turntable Rotation Button

The turntable rotation button (refer to Figure 7.4) is used with the joystick to rotate the turntable.

- To rotate the turntable clockwise press the turntable rotation button and then push the joystick forward, the direction of the red arrow.

- To rotate the turntable counterclockwise press the turntable rotation button and then pull the joystick backward, the direction of the yellow arrow.

Platform Level Button

The platform level button (refer to Figure 7.4) is used with the joystick to level the platform.

- To tilt the platform floor upward or away from the ground press the platform level button and then push the joystick forward, the direction of the red arrow.
- To tilt the platform floor downward or toward the ground press the platform level button and then push the joystick forward, the direction of the yellow arrow.

Horn

The horn button is at the bottom of the upper control panel (refer to Figure 7.4).

Press the button to sound the horn.

Platform Rotator

The platform can be rotated 150 degrees, 75 degrees to either side of the boom using a hand crank. The hand crank handle can be folded against the crank handle when it is not in use.

- Turn the hand crank (refer to Figure 7.5) counterclockwise to rotate the platform to the left and clockwise to rotate the platform to the right.

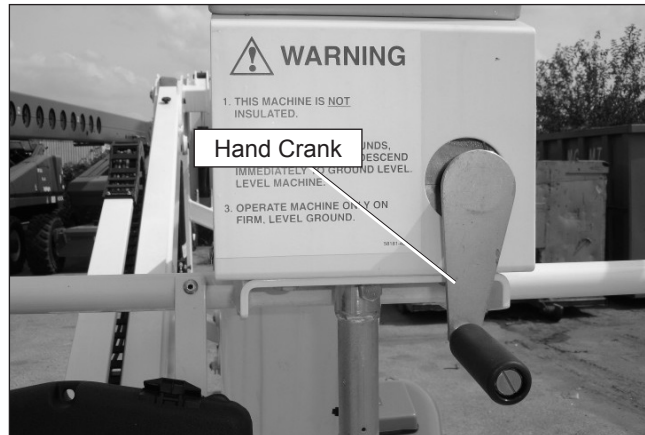

Figure 7.5 – Manual Platform Rotator

Position the platform perpendicular to the booms when driving or stowing the aerial platform.

Chapter 8 – Prestart Inspection

Potential service and safety problems may be detected by inspecting the aerial platform. This chapter includes information on properly inspecting the aerial platform and includes a prestart inspection check list at the end of the chapter to ensure that no areas are overlooked.

Warning

The potential for an accident increases when operating an aerial platform that is damaged or malfunctioning. Death or serious injury could result from such accidents. Do not operate the aerial platform if it is damaged or malfunctioning.

Perform a prestart inspection at the beginning of each shift, before using the aerial platform on the job. The inspection site must have a smooth and level surface.

Operator's Manual Holder

The manual holder is located at the front of the platform (refer to Figure 8.1).



Figure 8.1 – Operator's Manual Holder

To inspect the Operator's Manual holder:

1. Make certain the Operator's Manual holder is securely fastened in place.
2. Check to see that the proper Operator's Manual is in the holder.
3. Check to see that the manual is complete with all pages intact and in readable condition.
4. Make certain ANSI publication "Manual of Responsibilities for Dealers, Owners, Users, Operators, Lessors and Lessees of ANSI/SIAA92.5-2006 Boom-Supported Elevating Work Platforms" is in the manual holder.

Electrical System

Electrical power is supplied from eight, 360 amp, 6 volt batteries. These batteries supply 48 volt DC electrical power to operate the aerial platform drive system and 24 volt DC power to operate the control system.

Note

Refer to Chapter 6 for general battery maintenance and charging information.

Warning

Batteries give off hydrogen and oxygen that can combine explosively. Death or serious injury could result from a chemical explosion. Do not smoke or permit open flames or sparks when checking the batteries.

Caution

Even with low voltage electrical systems, severe arcing can occur. Electrical shock or component damage may result from contact with energized conductors. Use caution when working with any electrical device.

The batteries to power the machine are located in trays on each side of the aerial platform, refer to Figure 8.2.

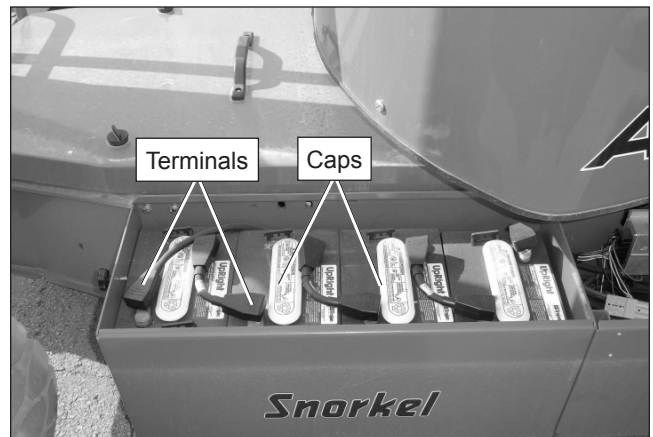

Figure 8.2 – Battery Tray

To access the batteries, release the latch on each side of the battery tray and remove the cover.

For optimal battery performance the battery fluid level must be maintained and the battery connections must be kept clean.

Battery Fluid Level

To inspect the battery fluid level:

1. Remove the caps from each battery (refer to Figure 8.2).
2. Visually check the battery fluid level making sure the level is within ¼" (6 mm) of the bottom of the filler neck inside each hole.
3. If necessary, add distilled water.

Note

Only use distilled water when refilling the batteries. Tap water may contain metallic solids such as iron which can reduce the life of the batteries.

4. Replace the caps on the batteries. The caps must be in place and tight during machine operation.

Battery Terminals

To inspect the battery terminals:

1. Check the top of each battery, the terminals, and cable ends. They should be clean and free of corrosion (refer to Figure 8.2).
2. If necessary, clean the top of the battery. Clean the terminals and cable ends with a wire brush or terminal cleaning tool.
3. Make sure all cable ends are securely fastened to the terminals.

Battery Charger

To inspect the battery charger:

1. At the lower controls, turn the start switch to the off position.
2. Turn the battery disconnect switch on (refer to Figure 8.3).

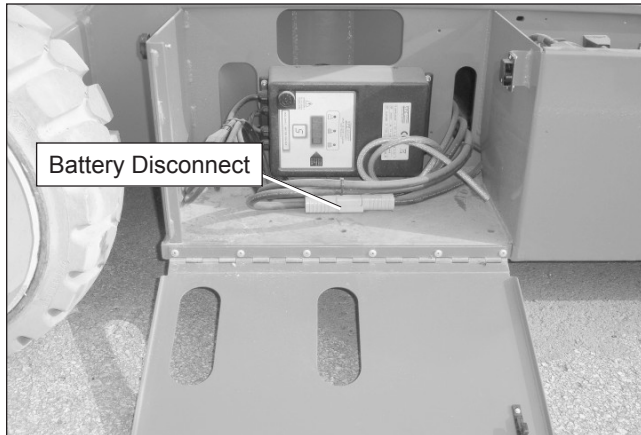

Figure 8.3 – Battery Disconnect Panel

2. Plug the batter charger into a properly grounded outlet (115 volt AC, 60 Hz) using a 3 conductor, 12 gauge (1.5 mm) or larger extension cord. The extension cord must be as short as possible and in good electrical condition.
3. After a short delay, visually inspect the battery charge indicator for proper charging rate (refer to Figure 8.3).
 - As the batteries become charged, the battery charge level on the battery charge indicator will increase.

4. Unplug the charger.

Battery Condition Indicator

To inspect the battery condition indicator from the upper controls:

1. Turn the battery disconnect switch on.
2. At the lower controls pull the emergency stop button outward (refer to Figure 8.4).

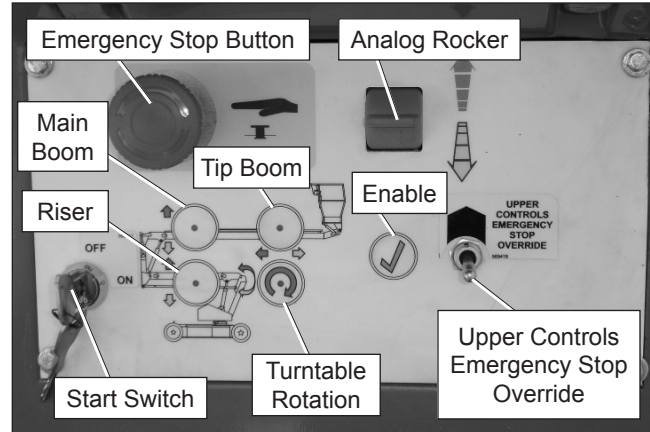

Figure 8.4 – Lower Controls

3. Insert the key into the start switch and turn it to the on position.
4. At the upper controls pull the emergency stop button outward (refer to Figure 8.5).

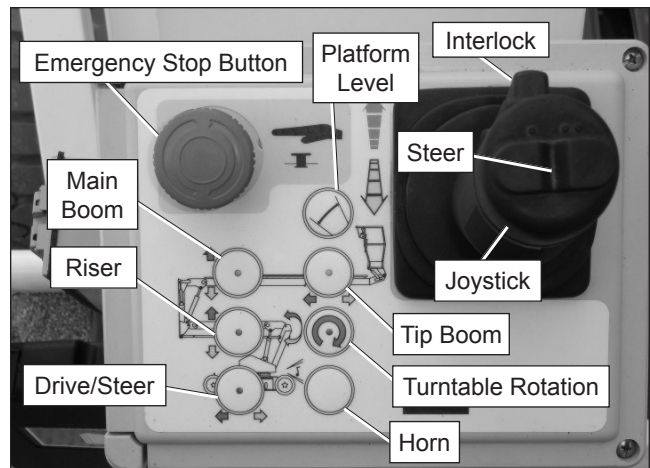

Figure 8.5 – Upper Controls

5. Check to see that the battery condition indicator displays a power reading at the upper controls (refer to Figure 8.5)

Cables and Wiring Harness

To inspect the cables and wiring harness:

1. Visually inspect all cables and wiring for wear and/or physical damage such as loose connections, broken wires, and frayed insulation.
2. Check the wiring in areas where a change in routing direction may cause them to become pinched.
3. Make sure the cables and wires are properly routed to avoid sharp edges, pinching, and scuffing.

Hydraulic System

Hydraulic power is supplied from a single stage hydraulic pump with a four horsepower DC electrical motor.

⚠ Danger

Hydraulic fluid escaping under pressure can have enough force to inject fluid into the flesh. Serious infection or reaction will result if medical treatment is not given immediately. In case of injury by escaping hydraulic fluid, seek medical attention at once.

The hydraulic reservoir is inside the right side of the chassis.

Fluid Level

To inspect the fluid level:

1. Make sure the aerial platform is fully stowed on a level surface.
2. Remove the drive control compartment cover at the rear of the chassis.
3. Visually check to make sure the fluid is visible in the sight glass (refer to Figures 8.6).

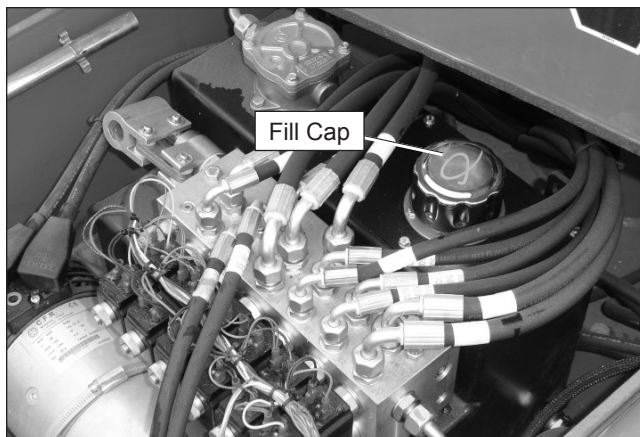

Figure 8.6 – Hydraulic Fluid Gauge

⚠ Caution

Not all hydraulic fluid is suitable to use in the hydraulic system. Some have poor lubricating characteristics and may increase component wear. Only use hydraulic fluid as recommended.

4. If necessary, remove the filler cap and add fluid of the proper type. Replace the cap making sure it is tightly in place.

Note

Refer to Chapter 2 for the proper type and grade of hydraulic fluid to use. The need to regularly add fluid indicates a leak that should be corrected.

Fluid Filter

Checking the condition of the hydraulic fluid filter is part of the machine maintenance schedule and should not be performed by the operator.

Hoses, Tubes, and Fittings

To inspect the hoses, tubes and fittings:

1. Inspect all hydraulic hoses, tubes, and fittings for wear, leakage, or damage (refer to Figure 8.7).

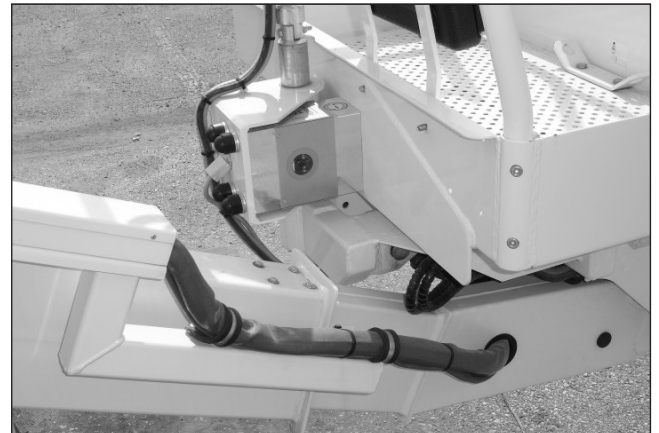

Figure 8.7 – Hoses, Tubes, and Fittings

2. Make sure the hoses are properly routed to avoid sharp edges, kinking, and scuffing.
3. Inspect the tubes for dents or other damage that may restrict fluid flow.
4. Make sure all hoses and tubes are held firmly in their support brackets.
5. Check under the chassis for fluid that has leaked. Hydraulic fluid leaks are easily visible on the ground.

Tires and Wheels

Visually inspect the tires and wheels (refer to Figure 8.8) to make sure they are suitable for service.



Figure 8.8 – Tires and Wheels

To inspect the tires and wheels:

1. Visually inspect the tires. They should be smooth without any cuts, gouges, or missing rubber that might affect aerial platform stability.
2. Check the wheels to see that the fasteners are in place and are not damaged or loose.

Lower Control Station

With no personnel in the platform, test the operation of each control from the lower controls (refer to Figure 8.9).

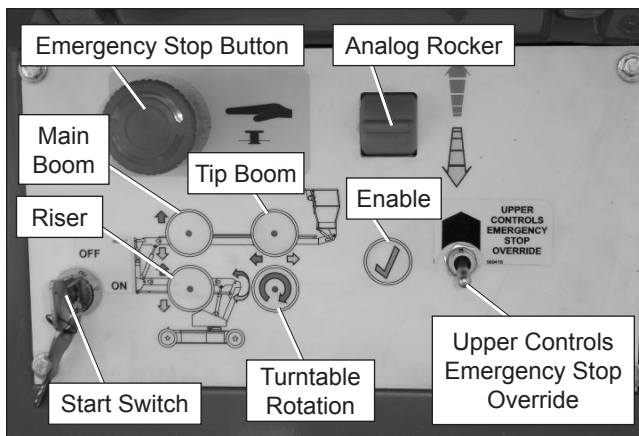

Figure 8.9 – Lower Controls

Operating Controls

Use the following procedure to operate the machine from the lower controls.

1. Make sure the battery disconnect is plugged in.
2. At the lower and upper controls, twist the emergency stop button clockwise to restore power.

3. Insert the key into the start switch and turn the switch to the on position.
4. Press and hold the ground operation button.

⚠ Danger

Pinch points may exist between moving components. Death or serious injury will result from becoming trapped between components, buildings, structures, or other obstacles. Make sure all personnel stand clear of the aerial platform while performing the prestart inspection.

⚠ Warning

The potential for an accident increases when operating an aerial platform that is damaged or malfunctioning. Death or serious injury could result from such accidents. Do not operate the aerial platform if it is damaged or malfunctioning.

5. Test the operation of each control in both directions.

Lowering Alarm

While the platform is lowering listen to ensure that the alarm sounds to warn personnel in the area that the platform is lowering.

Emergency Stop

To test the emergency stop button from the lower controls:

1. Push the emergency stop button inward to turn off electrical power.
2. Test the lower control functions to make sure they no longer operate.

Emergency Lowering

Use the following procedure to test the emergency lowering valve:

1. Partially raise the riser and main booms from the lower controls.
2. While standing clear of the chassis and platform, push the emergency lowering knob (refer to Figure 8.10) inward on each cylinder. The boom will begin to lower as the knob is pushed in.

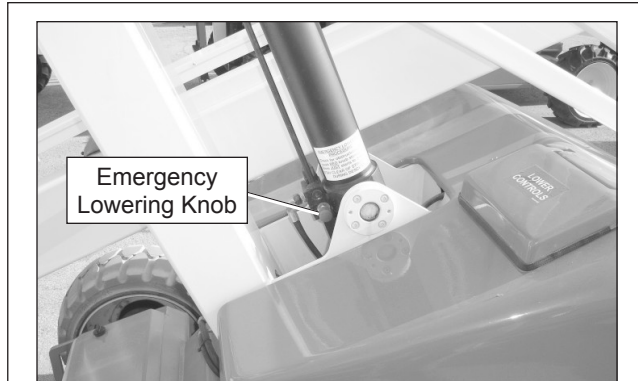

Rear of Chassis – Riser Boom Lift Cylinder

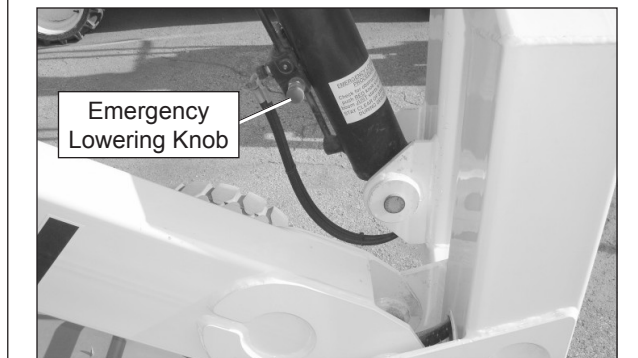

Front of Chassis – Main Boom Lift Cylinder

Figure 8.10 – Emergency Lowering Knobs

3. Release the knob to stop.
4. Make certain the knob is fully released after lowering the platform.

Manual Turntable Rotation

Use the following procedure to test the manual turntable rotation function:

1. Connect a 7/8" socket and ratchet to the rotation worm drive output shaft (refer to Figure 8.11).

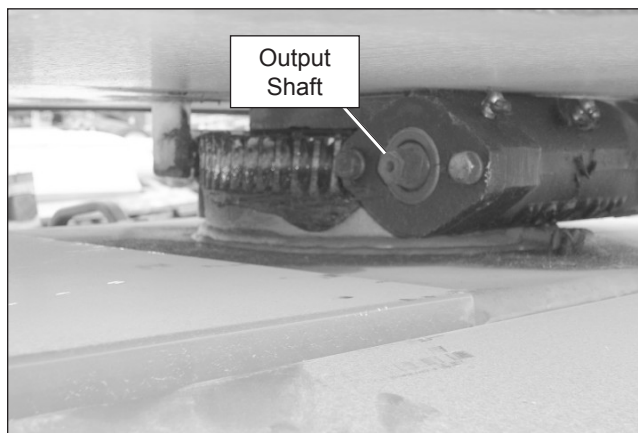

Figure 8.11 – Rotation Worm Drive

2. Verify that the turntable can be rotated in both directions using the ratchet.

Manual Tip Boom Retraction

Use the following procedure to test the manual tip boom retraction function:

1. From the lower controls, extend the tip boom a few feet and then press the emergency stop button.
2. Remove the cover from the front of the chassis to access the control valve.
3. Insert the handle (refer to Figure 8.12) into the hand pump holder and operate the pump to verify that the tip boom retracts.

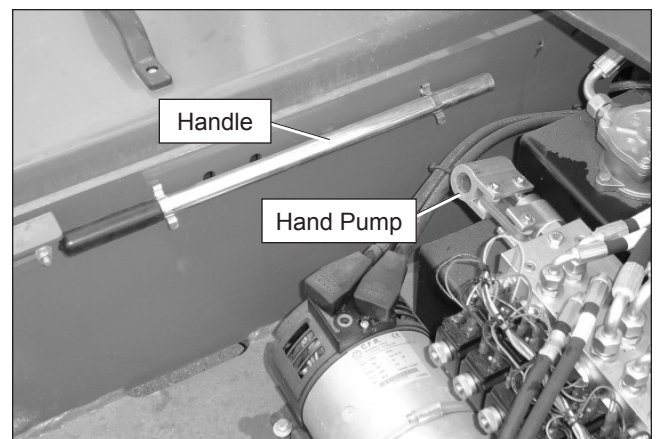

Figure 8.12 – Control Valve Under Front Chassis Cover

Flashing Light

The machine may be equipped with an optional flashing light mounted to the top of the counterweight.

To inspect the flashing light:

1. Turn the battery disconnect switch on.
2. At the lower controls, pull the emergency stop button outward and turn the start switch on.
3. Visually check to see that the light is flashing approximately one flash per second.

Note

There is not an off switch for the flashing light. The light cannot be turned off while the start switch is in the on position.

Structures

Visually inspect all weldments and related components. It is important to inspect the fasteners that connect the components.

Weldments

To inspect the weldments:

1. Visually inspect all weldments for abnormal wear, abrasion, or deformation that could cause interference between moving parts.
2. Inspect the welds on the structural components. Pay particular attention to boom welds. The area to be inspected should be clean and free of dirt and grease.
3. Look for visible cracks in the welds and at the weld to parent material joints. A bright light may be used to provide adequate visibility of the inspection area.

Boom Slide Pads

The main boom has slide pads (refer to Figure 8.13) between the main and tip boom selections.

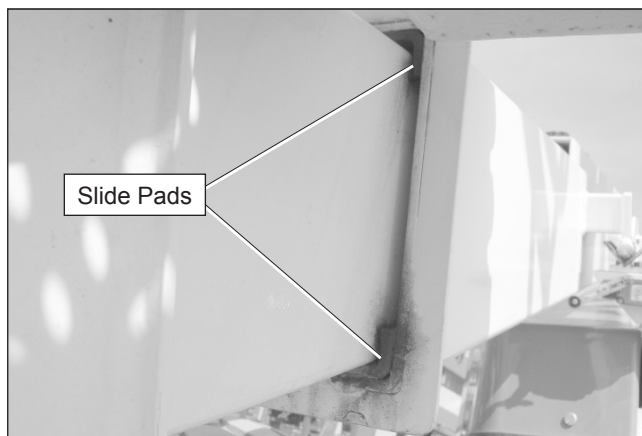

Figure 8.13 – Slide Pads at Tip End of Boom

To inspect the slide pads:

1. Use the lower controls to raise the main boom near horizontal. Extend the tip boom about 1' (30 cm).
2. Visually inspect the slide pads to make sure they are securely fastened to the main boom.
3. Inspect the surface where the pads contact the tip boom. The paint must be in place with no signs of bare metal.

Fasteners

To inspect the fasteners:

1. Visually inspect all fasteners to see that none are missing or loose.
2. Inspect all of the bolts, nuts, rollpins, collars, and snap rings that connect the booms and cylinders. They should all be present, tight, and not damaged in any way.

3. Raise the riser boom to access the inner race rotation bearing bolts in the turntable (refer to Figure 8.14). The outer race bolts can be viewed through the openings in the turntable. Rotate the turntable to inspect all of the outer race bolts.



Figure 8.14 – Rotation Bearing Bolts

4. Inspect the inner and outer race rotation bearing bolts to ensure that none are missing, damaged, or loose.

Upper Control Station

Inspect the platform and upper controls, after verifying all functions operated properly from the lower controls.

Guardrail System

The guardrail system includes (refer to Figure 8.15):

- A top rail
- A mid rail
- Entry gate
- Toeboards around the sides of the platform

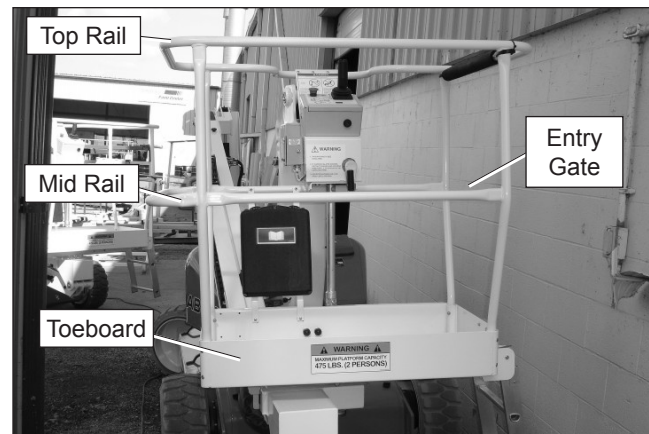

Figure 8.15 – Guardrail System

To inspect the guardrail system:

1. Visually inspect all components of the guardrail system. Make sure the rails and toeboards are all in place and free of any damage or deformation.

2. Visually inspect the rail and toeboard welds for cracks.
3. Visually check all bolts and nuts fastening the platform in place. They must be present and not show any signs of looseness.
4. Inspect the gravity gates to be sure they are present, not damaged, and move freely.

Lanyard Anchors

There are two lanyard anchors below the upper control panel (refer to Figure 8.16).

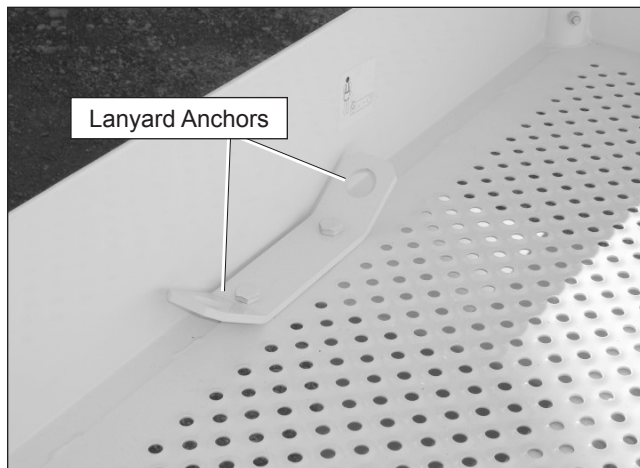

Figure 8.16 – Inside Rear of Platform

To inspect the lanyard anchors:

1. Visually inspect the lanyard anchors to make sure they are in place and not deformed.
2. Look for visible cracks in the welds and at the weld to parent material joints. A bright light may be used to provide adequate visibility of the inspection area.

Operating Controls

Use the following procedure to operate the machine from the upper controls:

1. Make sure the battery disconnect is plugged in.
2. At the lower controls, place the emergency stop switch and the start switch in the on position.
4. At the upper controls, pull the emergency stop button outward (refer to Figure 8.17).

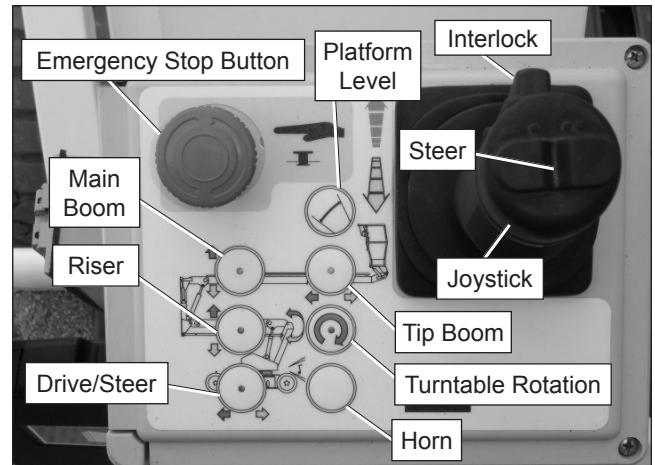

Figure 8.17 – Upper Controls

⚠ Danger

Pinch points may exist between moving components. Death or serious injury will result from becoming trapped between components, buildings, structures, or other obstacles. Make sure all personnel stand clear of the aerial platform while performing the prestart inspection.

⚠ Warning

The potential for an accident increases when operating an aerial platform that is damaged or malfunctioning. Death or serious injury could result from such accidents. Do not operate the aerial platform if it is damaged or malfunctioning.

7. Test the interlock switch by moving a boom function control without stepping on the foot switch. If movement occurs the interlock is not functioning properly. Do not operate the machine until the problem is corrected.
8. Test the operation of each control in both directions from the upper controls.
9. The drive range switch and maximum travel speeds are interlocked through limit switches on the riser and main boom that senses the position of the booms.
 - When the main boom is raised approximately 1 1/2' (3.8 cm) or extended approximately 1' (2.5 cm), the machine should travel in low speed only.
 - To operate in high speed the booms must be stowed.

Emergency Stop

To test the emergency stop button from the upper controls:

1. At the lower controls, turn the start switch to the on position and place the control selector switch in the upper control position.

2. At the upper controls, push the emergency stop button inward to turn off electrical power.
3. Verify that the upper control functions do not operate.

Horn

Operate the horn switch (refer to Figure 8.17) to ensure that it sounds to warn personnel in the area.

Electrical Power Outlet

To test the electrical power outlet:

1. Connect a source of 110 volt AC power to the power-input connector on the right side of the chassis (refer to Figure 8.18).

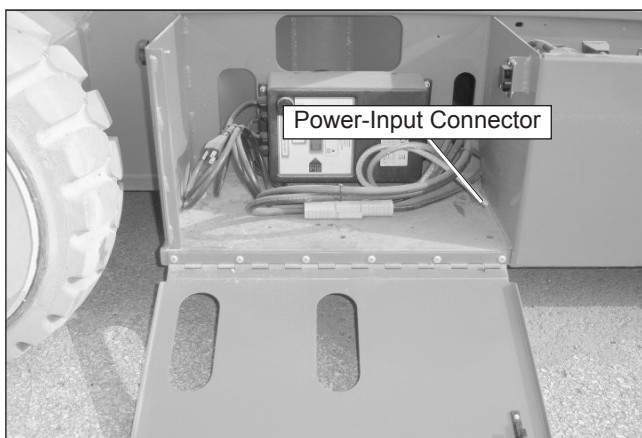

Figure 8.18 – Power-Input Connector

2. Plug an electrical tool into the receptacle at the platform and try to operate the tool to verify proper operation of the outlet.

The outlet is equipped with a ground fault circuit interrupter (GFCI). Use the following procedure to test the GFCI.

1. Push the test button (refer to Figure 8.19).

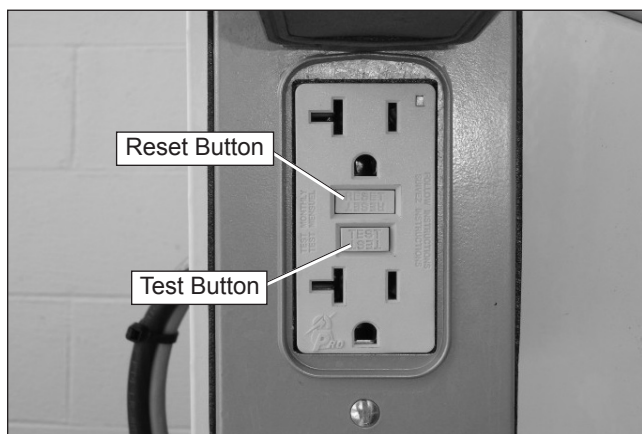

Figure 8.19 – Electrical Power Outlet

2. Plug an electrical tool into the outlet and verify the power is off.

- If the power was off, push the reset button to restore power.
- If the power was on, repair or replace the receptacle.

All Motion Alarm

The machine may be equipped with an optional all motion alarm.

- Operate the machine functions to ensure that the alarm sounds to warn personnel in the area that the aerial platform is in motion.

Placards and Decals

To inspect the placards and decals:

1. Inspect all safety and operational placards and decals. Make certain they are in place, in good condition, and are legible.
2. Clean the placards and decals with soap and water, and a soft cloth if the words or pictures cannot be seen.

⚠ Caution

Solvents may contain hazardous ingredients. Follow the manufacturer's label for proper use and disposal. Wear protective gloves and splash-proof safety glasses when using solvents.

3. Remove wet paint overspray with a natural biodegradable solvent and a soft cloth.
4. Replace any missing or illegible placards or decals before operating the aerial platform.

Placard and decal kits are available from Snorkel.

The safety related placards and decals are illustrated on the following page.



58181-400



56761-000

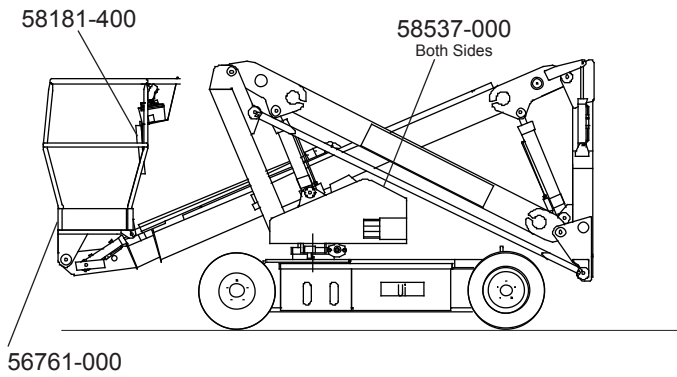

Right Side



58537-000

Prestart Inspection Checklist

Item	Inspect For	Ok
Operator's Manual	In place, all pages readable and intact	
Electrical System		
Batteries	Condition and charged for proper operation	
Battery fluid level and terminals	Proper level/clean, connectors tight	
Battery charger and condition indicator	Proper operation	
Cables and wiring harness	No wear or physical damage	
Hydraulic System		
Fluid level	Between full and add marks	
Hoses, tubes and fittings	No leaks	
Tires	Good condition	
Wheels	All wheel lug nuts present and properly torqued	
Lower Control Station		
Operating controls	Proper operation	
Emergency stop	Shuts off lower controls/proper operation	
Level Sensor	Sounds tilt alarm	
Flashing Light	Proper operation	
All Motion Alarm	Sounds when machine is operated and/or driven	
Structures		
Weldments	Welds intact, no damage or deformation	
Slide pad retainers	In place, no damage or deformation	
Fasteners	In place and tight	
Upper Control Station		
Guardrail system and lanyard anchors	Welds intact, no damage or deformation	
Operating controls	Proper operation	
Emergency stop	Shuts off upper controls/proper operation	
Horn	Sounds when activated	
Electrical power outlet	Proper operation	
Placards and Decals	In place and readable	

Chapter 9 – Operation

The aerial platform may be operated from either the lower or upper controls.

Danger

The aerial platform is not electrically insulated. Death or serious injury will result from contact with, or inadequate clearance from, an energized conductor. Do not go closer than the minimum safe approach distance as defined by ANSI.

Pinch points may exist between moving components. Death or serious injury will result from becoming trapped between components, buildings, structures, or other obstacles. Make sure there is sufficient clearance around the machine before moving the chassis, booms, or platform. Allow sufficient room and time to stop movement to avoid contact with structures or other hazards.

The aerial platform can tip over if it becomes unstable. Death or serious injury will result from a tip-over accident. Operate the aerial platform on a firm, flat, level surface. Avoid travel speeds and/or rough terrain that could cause sudden changes in platform position. Do not drive or position the aerial platform for elevated use near any drop-off, hole, slope, soft or uneven ground, or other tip-over hazard.

The platform rated work load is the total weight of the personnel and equipment that may be lifted in the platform.

The work loads are stated on the platform rating placard at the rear of the platform.

Danger

The aerial platform can tip over if it becomes unstable. Death or serious injury will result from a tip-over accident. Do not exceed the capacity values indicated on the platform rating placard.

Capacity values indicate the rated lifting capacity and do not indicate aerial platform stability.

The operator bears ultimate responsibility for ensuring that the aerial platform is properly set up for the particular conditions encountered.

Cold Weather Start-Up

If the ambient temperature is 32°F (0°C) or below, the hydraulic system oil may need to be warmed before operation.

Cold, thick hydraulic oil does not flow well and may cause delay in response to control movement. Cold hydraulic oil may also cause cavitation and pump damage.

Manually Warming the Hydraulic System

The hydraulic oil may be warmed by bottoming out the boom extension cylinder. Raise the main boom so it is horizontal and operate the boom retract function while the machine is stowed. With the cylinder bottomed out the oil flow will produce heat to warm the hydraulic oil.

Caution

Not all hydraulic fluid is suitable to use in the hydraulic system. Some have poor lubricating characteristics and may increase component wear. Only use hydraulic fluid as recommended.

Use cold weather hydraulic oil as recommended in the machine General Specifications in temperatures of 10°F (-13°C) or below.

Preparing for Operation

Before operating the aerial platform, make certain the batteries are charged and the charger is unplugged.

Use the following procedure to prepare the aerial platform for operation.

1. Perform a prestart inspection (refer to Chapter 8).
2. Make sure the battery disconnect is plugged in.
3. Close and latch the battery and hydraulic trays.

Lower Controls

The lower controls override the upper controls. This means that the lower controls can always be used to operate the platform regardless of the position of the upper control emergency stop button.

Boom, turntable, and platform functions may be operated from the lower controls. The lower controls may be used for initial set up of the aerial platform, and for testing and inspection.

Use the following procedure to operate boom, turntable, or platform functions using the lower controls.

1. Twist the emergency stop button clockwise at both the lower (refer to Figure 9.1) and upper controls (refer to Figure 9.2).

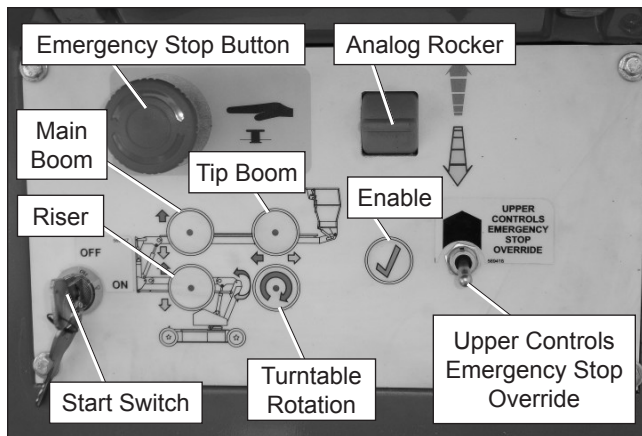

Figure 9.1 – Lower Controls

2. Insert the key into the start switch and turn the switch to the on position.
3. Press the appropriate function button.
4. Push and hold the analog rocker in the corresponding direction of the colored arrow for the selected function.
5. Release the analog rocker switch to stop movement.

Upper Controls

The upper controls may be used for driving the aerial platform and positioning the booms and platform while on the job.

Use the following procedure to operate machine functions using the upper controls.

1. Twist the emergency stop button clockwise at the lower controls (refer to Figure 9.1), insert the key into the start switch and turn the switch to the on position.
2. Enter the platform and securely close the gate.
3. Twist the emergency stop button clockwise at the upper controls (refer to Figure 9.2).

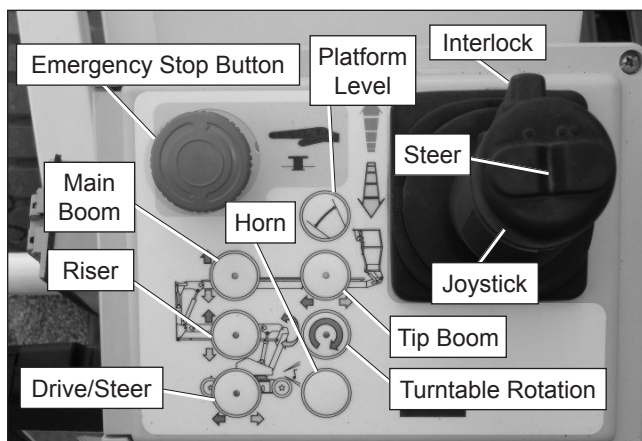

Figure 9.2 – Upper Controls

4. Attach the fall restraint lanyard to one of the anchor points.

Boom Operation

Use the following procedure to operate the turntable, boom, or platform functions.

1. Press the appropriate function button.
2. Squeeze and hold the interlock switch against the joystick and push and hold the joystick in the corresponding direction of the colored arrow for the selected function. Always look in the direction of movement.
3. To stop movement release the joystick to its neutral position or release the interlock switch.

Driving and Steering

⚠ Danger

The aerial platform can tip over if it becomes unstable. Death or serious injury will result from a tip-over accident. Do not drive an elevated aerial platform on soft, uneven, or sloping surfaces. Do not drive the machine on grades that exceed 36 percent.

For operation on grades up to 36 percent, it is recommended that the main boom be near horizontal and the jib be elevated just enough to provide adequate ground clearance.

A 36 percent grade is a 43" (1.1 m) vertical rise in 10' (3.05 m) horizontal length.

Avoid driving with the platform over the front end of the chassis. In this position the machine is difficult to control because:

- drive and steer control movements and their resulting machine movements are reversed.
- when driving fast, sudden turns or stops produce more severe reactions to platform occupants.
- more turning space is required to prevent the platform from colliding with obstacles several feet beyond the path of the tires.

⚠ Warning

Death or serious injury could result from improperly driving or steering the aerial platform. Read and understand the information in this manual and on the placards and decals on the machine before operating the aerial platform on the job.

The red and yellow arrows next to the function select buttons on the upper control placard indicates the direction the chassis will move when the drive or steer control is moved toward the corresponding color.

When the machine is in the stowed position, with the booms centered between the rear wheels, the direction of drive and steer control movement corresponds with the direction of chassis movement.

When the turntable is rotated from the stowed position, with the booms to either side of or in front of the chassis, the direction of control movement does not correspond with the direction of chassis movement.

- To avoid confusion, always drive to the work area or move between work areas with the turntable and booms in the stowed position.
- After arriving at the work area, the booms may be positioned to the side or the front of the chassis for final positioning.
- Always look in the direction of movement as indicated by the directional arrows.

Use the following procedure to operate the drive and steer functions.

1. Press the drive/steer button.
3. Squeeze and hold the interlock switch against the joystick. Push the drive joystick forward to move the chassis forward, the direction of the red arrow. Pull the joystick backward to move the chassis backward, the direction of the yellow arrow. The drive speed is proportional to the joystick position.
4. To stop drive motion, return the joystick to neutral.
5. The steer switch is a momentary contact, rocker switch on top of the drive joystick. The switch controls the two front wheels to steer the aerial platform. Squeeze and hold the interlock switch against the joystick.
 - To steer to the right, hold down the right side of the steer switch.
 - To steer to the left, hold down the left side of the steer switch.

Note

The steering wheels are not self-centering. Set the steering wheels straight ahead after completing a turn.

6. After driving to the desired location, release the interlock switch, or push the emergency stop button to apply the parking brakes.

Drive Speeds

The drive speed is proportional to the joystick position. The farther the joystick is moved, the faster the travel speed.

Always slow down before traveling over any sloped surface.

Drive speed range is interlocked through a limit switch that sense the main and riser boom position.

- When either boom is elevated, only the slowest drive speed will work regardless of the joystick position.
- To avoid a sudden speed change from high to low elevated boom speed, always bring the machine to a stop before raising the booms from the stowed position.

Warning

The potential for an accident increases when safety devices do not function properly. Death or serious injury could result from such accidents. Do not alter, disable, or override any safety device.

Do not use the aerial platform if it drives faster than 0.75 miles per hour (33 feet in 30 seconds) when any of the booms are out of the stowed position.

All Motion Alarm

The optional all motion alarm sounds loud intermittent beeps anytime the machine functions are being operated.

Electrical Power Outlet

The electrical outlet at the platform has two, 3-prong, 110 volt AC electrical connectors. Their combined output is limited by a 15 amp circuit breaker.

To use the outlet, plug a source of power into the power-input connector on the right side of the chassis (refer to Figure 9.3). Unplug the source of power before moving the aerial platform.

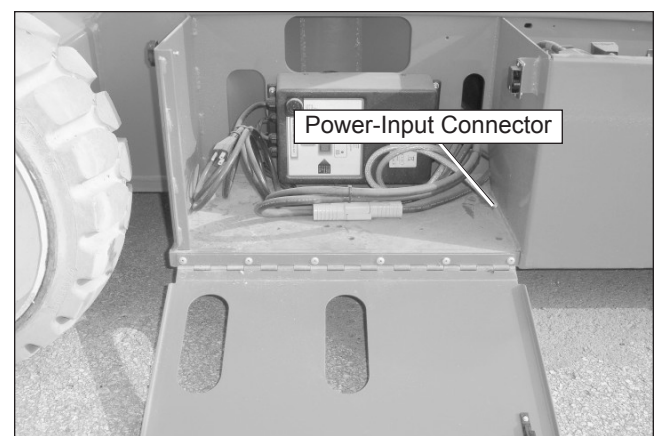

Figure 9.3 – Power-Input Connector

Chapter 10 – Stowing and Transporting

To prevent unauthorized use and damage, properly stow the aerial platform at the end of each work day. It must also be properly stowed while transporting.

Stowing

The properly stowed position is shown in Figure 10.1.

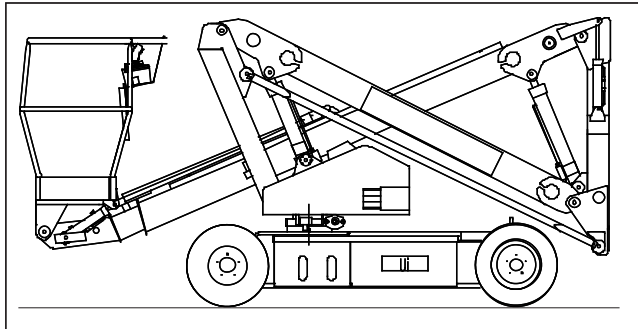

Figure 10.1 – Stowed Position

Use the following procedure to properly stow the aerial platform.

1. Rotate the platform so it is perpendicular to the end of the boom.
2. Fully retract the tip boom and then fully lower the riser and main booms.
3. Center the booms between the rear wheels.
4. Push the lower controls emergency stop button inward. Place the start switch in the off position and remove the key.
5. Unplug the battery disconnect.
6. Stow the step and make certain the tray covers are in place and securely fastened.

Transporting

The aerial platform may be moved on a transport vehicle. Depending on the particular situation, the aerial platform may be driven, winched, or hoisted onto a vehicle such as a truck or trailer. Driving is the preferred method.

Danger

The aerial platform can tip over if it becomes unstable. Death or serious injury will result from a tip-over accident. Do not drive on ramps that exceed 30 percent grade, or where conditions of the ramp could cause driving to be hazardous.

Drive the aerial platform onto the transport vehicle if the ramp incline is within the 36 percent grade capability of the aerial platform.

A 36 percent grade is a 43" (1.1 m) vertical rise in 10' (3.05 m) horizontal length.

Use a winch to load and unload the aerial platform on ramps that exceed the grade capability of the machine. A winch may also be used when conditions of the ramp could cause driving to be hazardous.

The equipment used to load, unload, and transport the aerial platform must have adequate capacity. Refer to Chapter 2 to determine the approximate weight of the aerial platform.

The user assumes all responsibility for:

- Choosing the proper method of transportation.
- Choosing the proper selection and use of transportation and tie-down devices.
- Making sure the equipment used is capable of supporting the weight of the aerial platform.
- Making sure all manufacturer's instructions and warnings, regulations and safety rules of their employer, the DOT and/or any other state or federal law are followed.

Driving

Use the following procedure to drive the aerial platform onto the transport vehicle.

1. Locate the transport vehicle so it is in a straight line with the loading ramp.
2. Chock the vehicle wheels so it cannot roll away from the ramp while the machine is loaded.
3. Remove any unnecessary tools, materials, or other loose objects from the platform.
4. Drive the machine to the foot of the loading ramp with the front wheels nearest the ramp. Make sure the machine is centered with the ramps and that the steering wheels are straight.
5. Rotate the platform so it is perpendicular to the boom.
6. Retract the tip boom and raise the main boom so it is horizontal.
7. Rotate the turntable slightly to the side so you can see the front wheels.
8. Verify that the machine wheels, loading ramps, and transport vehicle are aligned.

⚠ Danger

The aerial platform can tip over if it becomes unstable. Death or serious injury will result from a tip-over accident. Set the drive range to low before driving up or down a grade.

9. Drive the aerial platform onto the transport vehicle in a straight line through the grade transitions with minimal turning.
10. Rotate the turntable to align the main boom between the rear wheels.
11. When driving down the ramp, always back the machine with the platform on the downhill side only.

Winching

Use the following procedure to winch the aerial platform onto the transport vehicle.

1. Locate the transport vehicle so the aerial platform will not roll forward after it is loaded.
2. Remove any unnecessary tools, materials, or other loose objects from the platform.
3. Drive the machine to the foot of the loading ramp with the front wheels nearest the ramp. Make sure the machine is centered with the ramps and that the steering wheels are straight.
4. Fully retract the booms. Lower the main boom as much as possible making sure there is adequate ground clearance between the platform and the ramp.
5. Attach the winch to the tie-down lugs (refer to Figure 10.2) on the front of the chassis.



Figure 10.2 – Front Tie-Down/Lifting Lugs

6. At each drive wheel, using a 6 mm Allen wrench, turn the socket screw (refer to Figure 10.3) fully clockwise.



Figure 10.3 – Drive Wheel

7. Use the winch to position the aerial platform on the transport vehicle.

⚠ Warning

The aerial platform is free to move when the drive hubs are disabled. Death or serious injury could result. Re-enable the drive hubs before operating the aerial platform.

8. At each drive wheel, turn the socket screw fully counterclockwise to its original position.
9. Start the machine and operate the drive control in forward and reverse several times to engage the drive hubs.

Hoisting

Use a four point sling arrangement attached to the lifting lugs when hoisting the aerial platform. Machine damage can occur if the sling is attached to the booms, turntable, or platform.

⚠ Warning

The potential for an accident increases when the aerial platform is lifted using improper equipment and/or lifting techniques. Death or serious injury could result from such accidents. Use proper equipment and lifting techniques when lifting the aerial platform.

Know the weight of the aerial platform and the capacity of the lifting devices before hoisting.

- Lifting devices include the hoist or crane, chains, straps, cables, hooks, sheaves, shackles, slings, and other hardware used to support the machine.
- The empty vehicle weight is stamped on the serial number placard and is listed in Chapter 2.

The user assumes all responsibility for:

- Making sure the equipment used is capable of supporting the weight of the aerial platform.
- Making sure all manufacturer’s instructions and warnings, regulations and safety rules of their employer and/or any state or federal law are followed.

Use the following procedure to hoist the aerial platform onto the transport vehicle.

1. Properly stow the aerial platform.
2. Inspect the front lifting lugs (refer to Figure 10.2) and the rear lifting lugs (refer to Figure 10.4) to make sure they are free of cracks and are in good condition. Have any damage repaired by a qualified service technician before attempting to hoist the machine.

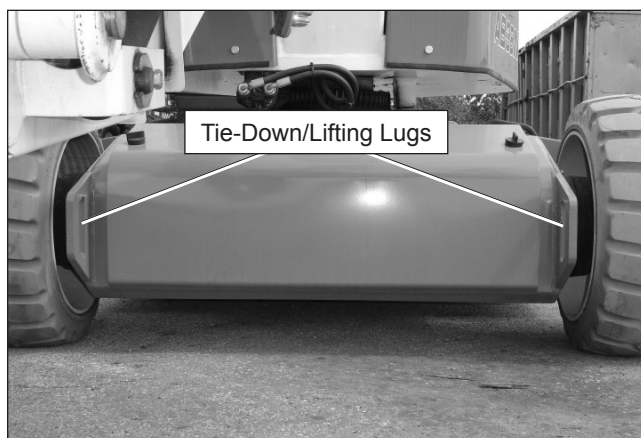

Figure 10.4 – Rear Tie-Down/Lifting Lugs

3. Remove all personnel, tools, materials, or other loose objects from the platform.
4. Connect the chains or straps to the lifting lugs using bolted shackles. Hooks that fit properly in the lugs and that have latching mechanisms to prevent them from falling out under a slack line condition may also be used.

Do not run the sling cable through the lifting lugs.

- Cable damage and/or failure can result from the cable contacting the sharp corners of the lug.
 - There is no effective way of putting a corner protector in the hole of the lifting lug.
5. Use spreader bars of sufficient length to keep the chains, straps, or cables from contacting the turntable, booms, and steer cylinders.
 - When using cables, use rigid corner protectors at any point where the cable contacts sharp corners to prevent damaging the cable.
 - Careful rigging of the spreaders is required to prevent machine damage.

6. Adjust the length of each chain or strap so the aerial platform remains level when raised off the ground.
7. Use the hoist or crane to carefully raise and position the aerial platform onto the transport vehicle.

Securing for Transport

Use the following procedure to secure the aerial platform on the transport vehicle.

1. Chock the wheels and Remove all personnel, tools, materials, or other loose objects from the platform.
3. Raise the main boom about 1' (0.3 m).
4. Place a large wood block under the platform support braces (refer to Figure 9.5). Lower the platform so it rests on the wood block.

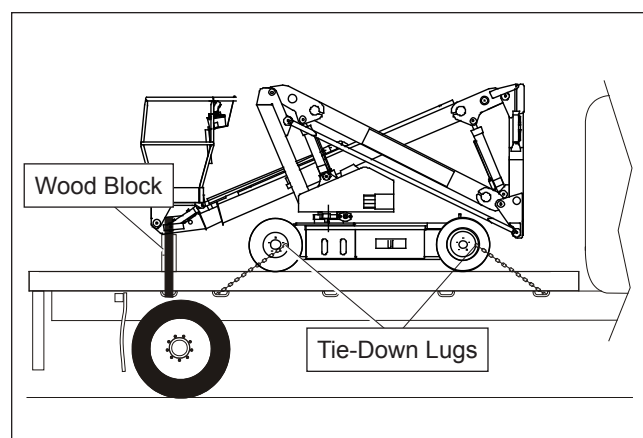

Figure 10.5 – Platform

5. Place the lower controls emergency stop switch in the off position. Turn the start switch to the off position and remove the key.
6. Unplug the battery disconnect switch off and close and latch the battery trays and chassis covers.
7. Use wire-ties to fasten the gravity gate to the guardrails to prevent them from bouncing.

⚠ Caution

Ratchets, winches, and come-alongs may produce enough force to damage machine components. Do not over tighten the straps or chains when securing the aerial platform to the transport vehicle.

8. Use a nylon strap to securely fasten the platform against the wood block.
9. Use chains or straps to securely fasten the aerial platform to the transport vehicle using the tie-down lugs as attachment points. Proper tie-down and hauling are the responsibility of the carrier.

Chapter 11 – Emergency Operation

If the main hydraulic system fails:

- The platform may be lowered using the emergency lowering knobs.
- The turntable may be manually rotated.
- The tip boom may be manually retracted.
- The machine may be towed if the drive system fails.
- Refer to Emergency Lowering, or Towing for the appropriate procedure.

Emergency Lowering

Use the following procedure to lower the platform.

⚠Warning

The potential for an accident increases when safety devices do not function properly. Death or serious injury can result from such accidents. Immediately push the emergency stop button inward to disable the control system before using the emergency lowering system in the event of an emergency.

1. Immediately push the emergency stop button inward to disable the control system in the event of an emergency.
2. Locate the emergency lowering knobs at the base end of the lift cylinders (refer to Figure 11.1).

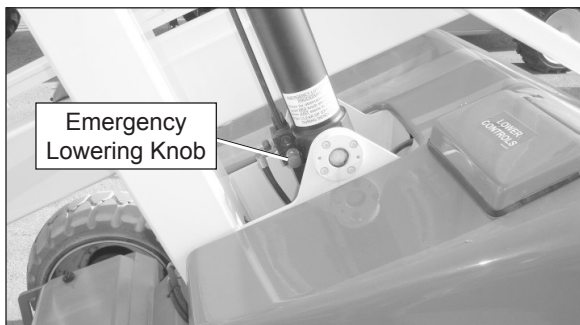

Rear of Chassis – Riser Boom Lift Cylinder

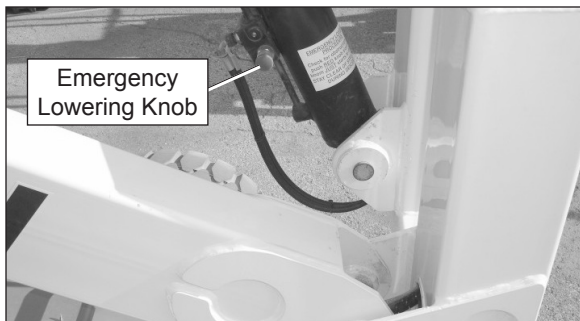

Front of Chassis – Main Boom Lift Cylinder

Figure 11.1 – Emergency Lowering Knobs

3. Make sure there is nothing in the way to obstruct the platform when it lowers.

⚠Danger

Pinch points exist on the aerial platform. Death or serious injury will result from becoming trapped between the platform and the chassis. Make sure all personnel stand clear while lowering the platform with the emergency lowering knob.

4. While standing clear of the chassis and platform, push the emergency lowering knob (refer to Figure 8.10) inward on the appropriate cylinder. The boom will begin to lower as the knob is pushed in.
5. Release the knob to stop.
6. Make certain the knob is fully released after lowering the platform.

Manual Turntable Rotation

Use the following procedure to manually rotate the turntable:

1. Connect a 7/8" socket and ratchet to the rotation worm drive output shaft (refer to Figure 11.2).

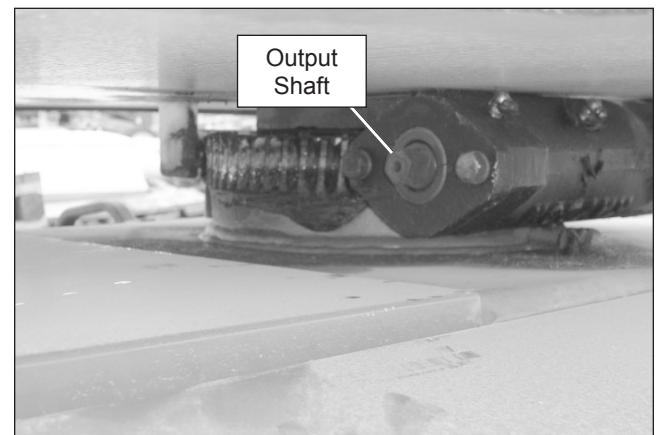

Figure 11.2 – Rotation Worm Drive

2. Use the ratchet to manually rotate the turntable

Manual Tip Boom Retraction

Use the following procedure to manually retract the tip boom:

1. Remove the cover from the front of the chassis to access the control valve.
2. Insert the handle (refer to Figure 11.3) into the hand pump holder and operate the pump to retract the tip boom.

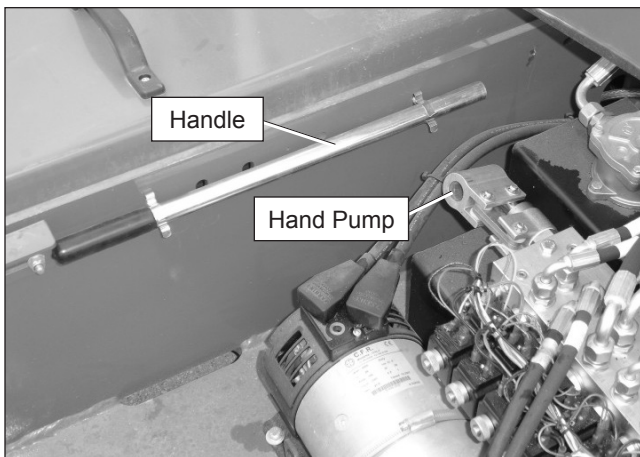

Figure 11.3 – Control Valve Under Front Chassis Cover

Towing

The aerial platform may be pushed or pulled after disengaging the brakes. Use the following procedure to manually disengage the brakes.

⚠Warning

The aerial platform is free to move when the brakes are released. Death or serious injury can result. Re-enable the brakes before operating the aerial platform.

1. Check the wheels to prevent uncontrolled motion of the aerial platform.

2. At each drive wheel, using a 6 mm Allen wrench, turn the socket screw (refer to Figure 11.4) fully clockwise.



Figure 11.4 – Drive Wheel

3. Do not exceed 1' per second (0.3 m/sec) when towing.

⚠Warning

The aerial platform is free to move when the brakes are released. Death or serious injury can result. Re-enable the brakes before operating the aerial platform.

4. After moving the aerial platform, turn the socket screw (refer to Figure 11.4) on each drive wheel fully counterclockwise.

Chapter 12 – Troubleshooting

The troubleshooting chart may be used to locate and eliminate situations where machine operation may be interrupted. If the problem cannot be corrected with the

action listed, stow the machine and remove it from service. Repairs must be made by qualified maintenance personnel.

Troubleshooting Chart

Symptom	Possible Cause	Corrective Action
Will not work from lower or upper controls.	Batteries discharged.	Recharge the batteries.
	Battery charger plugged in.	Unplug the battery charger.
	The main system circuit breaker on the lower control panel has tripped.	Push the main system circuit breaker button back in. If the button pops back out, refer the problem to a qualified service technician.
	Battery disconnect switch is off.	Turn the battery disconnect switch on.
Will not work from lower or upper controls after battery charger is unplugged.	Normal operation after unplugged.	Wait approximately 60 seconds for the battery charge indicator light to shut off.
All functions stop working.	Low fluid level in reservoir.	Check hydraulic fluid level . Add correct type of fluid if necessary.
	Motor or pump failure.	Manually stow the machine using the emergency power system.
	Electrical system malfunction.	Lower the boom using the emergency power system.
	Batteries discharged.	Recharge batteries.
Lower controls do not work.	Switches are set wrong.	Plug the battery disconnect in and then at the lower controls: <ul style="list-style-type: none"> • Turn the start switch to the off position. • Twist the emergency stop button clockwise at the lower and upper controls. • Turn the start switch to the on position.
Upper controls do not work.	Switches are set wrong.	Plug the battery disconnect in and then at the lower controls: <ul style="list-style-type: none"> • Turn the start switch to the off position. • Twist the emergency stop button clockwise at the lower and upper controls. • Turn the start switch to the on position. From the upper controls: <ul style="list-style-type: none"> • Twist the emergency stop button clockwise at the lower and upper controls.

Symptom	Possible Cause	Corrective Action
Battery charge indicator does not indicate a reading when charging batteries.	No source of power.	Make sure power source is plugged in and turned on.
	Circuit breaker is tripped.	Unplug the charger until the internal circuit breaker has reset.
Boom and drive functions seem sluggish.	Hydraulic oil is cold and thick.	Use cold weather hydraulic oil as recommended for weather conditions. Warm oil before operating the machine.
Riser and/or main boom drifts down.	Hydraulic system malfunction.	Stow the machine and do not operate until repairs are made.
	Emergency lowering knob pushed in.	Pull knob outward to normal operating position.
Drive functions will not work.	Load capacity exceeded.	Remove load from platform. Refer to platform capacity placard for maximum capacity.
	Machine is not on a level surface or too steep of a grade.	Lower the platform and drive to a level surface.
	Drive hubs are disengaged.	Turn drive wheel disconnect socket screws fully counterclockwise.
	Low hydraulic system pressure.	Stow the machine and do not operate until repairs are made.
Can not reach maximum drive speed of 2.5 mph (4 km/h).	Booms are not retracted and lowered.	Fully retract and lower the boom.
Wheels will not turn when winching.	Drive hubs are engaged.	Turn drive wheel disconnect plates around so nipples point inward.
Tilt alarm does not work.	Booms are stowed.	Normal operation. The tilt alarm is operational when the booms are near horizontal.
Circuit breaker will not reset.	Electrical circuit has not had time to cool.	Wait a minute or two for circuit to cool, then push circuit breaker button in to reset.
	Electrical system malfunction.	Stow the machine and do not operate until repairs are made.
Electrical outlet does not work.	Power supply not plugged in.	Plug a source of power into the power-input connector on the wiring box.
	GFCI is tripped.	Push reset button on outlet.
Hydraulic fluid temperature of 200°F (93°C) or more.	Prolonged boom operation.	Stop operation until fluid cools.
	High pressure fluid return to reservoir caused by kinked or twisted hose.	Remove the kink or twist from the hose. Let fluid cool before operating.
	Hydraulic system component failure.	Stow the machine and do not operate until repairs are made.
Severe hydraulic leak.	Failure of hose, tube, fitting, seal, etc.	Do not operate machine until repairs are made.

When a fault code is displayed on the upper control panel, the chart below may be used to locate and eliminate situations where machine operation may be interrupted.

If the problem cannot be corrected with the action listed, stow the machine and remove it from service. Repairs must be made by qualified maintenance personnel.

Fault Code	Possible Cause	Corrective Action
01 - 39	<p>Upper or lower control function depressed during machine start up.</p> <hr/> <p>Faulty lower or upper control panel or machine error.</p>	<p>From the upper controls make sure:</p> <ul style="list-style-type: none"> • no selector buttons are depressed. • the analog rocker is in neutral. • the interlock switch is not depressed. • the joystick is in neutral. • the steer switch is not depressed. <p>From the lower or upper controls:</p> <ul style="list-style-type: none"> • cycle machine power off then on by pressing the emergency stop button and then twisting the button clockwise to restore power. <hr/> <p>Stow the machine and do not operate until repairs are made.</p>
68	Low battery fault.	Charge the batteries.
51 - 67, 69	Machine error.	Stow the machine and do not operate until repairs are made.

Appendix A – Glossary

aerial platform – a mobile device that has an adjustable position platform, supported from ground level by a structure.

ambient temperature – the air temperature of the immediate environment.

authorized personnel – personnel approved as assigned to perform specific duties at a specific location.

base – the relevant contact points of the aerial platform that form the stability support (e.g. wheels, casters, outriggers, stabilizers).

battery tray – a compartment that holds the batteries.

boom – a movable cantilever beam which supports the platform.

center of gravity – the point in the aerial platform around which its weight is evenly balanced.

chassis – the integral part of the aerial platform that provides mobility and support for the booms.

fall restraint – a system that is used while working on a boom lift within the boundaries of platform guardrails to provide restraint from being projected upward from the platform. This system includes a harness or belt, lanyard, and a lanyard anchor. Federal OSHA, ANSI, and Snorkel require the use of additional fall protection beyond the platform guardrails on boom supported aerial platforms.

floor or ground pressure – the maximum pressure, expressed in pounds per square inch, a single wheel concentrates on the floor or ground.

gradeability – the maximum slope that the aerial platform is capable of travel.

ground fault circuit interrupter (GFCI) – a fast-acting circuit breaker that opens to stop electrical circuit flow if it senses a very small current leakage to ground. The GFCI is used to protect personnel against a potential shock hazard from defective electrical tools or wiring.

guardrail system – a vertical barrier around the platform to prevent personnel from falling.

hazardous location – any location that contains, or has the potential to contain, an explosive or flammable atmosphere as defined by ANSI/NFPA 505.

level sensor – a device that detects a preset degree of variation from perfect level. The level sensor is used to sound an alarm if operating on a slope greater than the preset value.

lower controls – the controls located at ground level for operating some or all of the functions of the aerial platform.

main boom – a boom assembly located between the riser and the jib.

manufacturer – a person or entity who makes, builds or produces an aerial platform.

maximum travel height – the maximum platform height or the most adverse configuration(s) with respect to stability in which travel is permitted by the manufacturer.

maximum wheel load – the load or weight that can be transmitted through a single wheel to the floor or ground.

Minimum Safe Approach Distance – the minimum safe distance that electrical conductors may be approached when using the aerial platform. Also called M.S.A.D.

operation – the performance of any aerial platform functions within the scope of its specifications and in accordance with the manufacturer's instructions, the users work rules, and all applicable governmental regulations.

operator – a qualified person who controls the movement of an aerial platform.

personal fall arrest system – a fall protection system that is used while working on an unprotected edge (such as a roof top with no guardrail). This system includes a harness, lanyard or other connecting device, a fall arrestor, an energy absorber or decelerator, an anchorage connector, and a secure anchorage such as a building beam, girders or columns. An aerial platform is not a fall arrest anchorage.

platform – the portion of an aerial platform intended to be occupied by personnel with their tools and materials.

platform height – the vertical distance measured from the floor of the platform to the surface upon which the chassis is being supported.

prestart inspection – a required safety inspection routine that is performed daily before operating the aerial platform.

qualified person – a person, who by reason of knowledge, experience, or training is familiar with the operation to be performed and the hazards involved.

rated work load – the designed carrying capacity of the aerial platform as specified by the manufacturer.

riser – the structure that connects the riser boom to the main boom.

riser boom – an articulating boom section. The riser boom is between the turntable and the main boom.

stow – to place a component, such as the platform, in its rest position.

tip boom – a telescopic boom section that extends and retracts from within the main boom. The tip boom is nearest the platform.

turning radius – the radius of the circle created by the wheel during a 360° turn with the steering wheels turned to maximum. Inside turning radius is the wheel closest to the center and outside turning radius is the wheel farthest from the center.

turntable – the structure above the rotation bearing which supports the booms. The turntable rotates about the centerline of rotation.

unrestricted rated work load – the maximum designed carrying capacity of the aerial platform allowed by the manufacturer in all operating configurations.

upper controls – the controls located on or beside the platform used for operating some or all of the functions of the aerial platform.

wheelbase – the distance from the center of the rear wheel to the center of the front wheel.

working envelope – the area defined by the horizontal and vertical limits of boom travel that the platform may be positioned in.

working height – platform height plus six feet.



Product Warranty

1. Snorkel warrants each new machine manufactured and sold by it to be free from defects in material and workmanship for a period of one (1) year from date of delivery to a Customer. The warranty will apply subject to the machine being operated in accordance with the rules, precautions, instructions and maintenance requirements outlined in the Snorkel Operator's and Repair Parts Manuals.
2. Snorkel further warrants the structural components, specifically the mainframe chassis, turntable, booms and/or scissor arms of each new machine manufactured by it to be free from defects in material and workmanship for an additional period of four (4) years. Any such part or parts which, upon examination by the Snorkel Warranty Department, are found to be defective will be replaced or repaired by Snorkel through its local Authorised Dealer. The structural warranty specifically excludes adverse affects on the machine structure arising from damage, abuse or misuse of the equipment.
3. Machines may be held in an authorised Distributor stock for a maximum of six (6) months from the date of shipment from Snorkel, before the warranty period is automatically initiated.
4. It is the responsibility of the Distributor to complete and return a Predelivery/Warranty registration, before the act of rental/loan/demonstration of the machine or delivery to an end user.
5. The Customer and Dealer shall not be entitled to the benefits of this warranty and Snorkel shall have no obligations here under unless the "Predelivery and Inspection Record" has been properly completed and returned to the Snorkel Warranty department within fifteen (15) days after delivery of the Snorkel product to the Customer or Dealer's demonstration/rental fleet. Snorkel must be notified, in writing, within ten (10) days, of any machine sold to a Customer from a Dealer's rental fleet during the warranty period.
6. Any part or parts which upon examination by the Snorkel Product Support Department are found to be defective within the specified warranty period, will be replaced or repaired at the sole discretion of Snorkel, through Snorkel directly or an authorised Distributor, at no charge. Any parts replaced under warranty must be original Snorkel parts obtained through Snorkel directly or an authorised Distributor, unless expressly agreed otherwise in writing and in advance by Snorkel's Warranty Department.
7. All parts being claimed under warranty must be held available for return and inspection upon request for a period of 90 days from date of claim submission, it is necessary that all parts are individually tagged or marked with their part number and the warranty claim number. After 90 days all parts replaced under warranty which have not been returned to Snorkel should be destroyed. Failure to produce parts requested by the Warranty Administrator for inspection within a period of 14 days will result in the claim being automatically rejected in full. Materials returned for warranty inspection must have the following procedure:
 - Carefully packaged to prevent additional damage during shipping
 - Drained of all contents and all open ports capped or plugged
 - Shipped in a container tagged or marked with the RMA number
 - Shipped PREPAID. Any item(s) returned for warranty by any other means maybe refused and returned, unless prior approval is agreed with Snorkel.



Product Warranty

8. At the direction of the Snorkel Warranty Department, any component part(s) of Snorkel products to be replaced or repaired under this warranty program must be returned freight prepaid for inspection. An RMA (Returns Material Authorisation) must be requested from Snorkel Warranty Department, a copy to be placed with the returning component part(s).
9. All warranty replacement parts will be shipped freight prepaid (standard charge) from the Snorkel Parts/Service Department or from the Vendor to Dealer or Customer.
10. All warranty claims are subject to approval by Snorkel Service Department. Snorkel reserves the right to limit or adjust claims with regard to defective parts, labor or travel time based on usual and customary guidelines.

REPLACEMENT PARTS WARRANTY

- Any part replaced under this limited warranty is not subject to further warranty cover beyond the normal warranty period of the machine upon which the part was installed.
- Any replacement parts sold (not delivered under a warranty claim) will be subject to a warranty period of (6) six months from the date of invoice.
- Parts held by a Distributor are covered under warranty for a period of (12) twelve months from the date of invoice, provided that those parts have been subject to appropriate storage to prevent damage and deterioration.

CLAIM PROCEDURE

The Snorkel Warranty Department must be notified within (48) forty-eight hours of any possible warranty situation during the applicable warranty period. Personnel performing major warranty repair or parts replacement must obtain specific approval by the Snorkel Warranty Department prior to performing the warranty repair or replacement.

When a Distributor/Customer perceive a warranty issue to exist the following steps must be adhered to:

- All warranty claims must be submitted within 30 days of the date of the machine repair
- All correspondence in respect of the claim to be on an official Snorkel warranty claim form as supplied by Snorkel's Warranty Department
- Allocate a warranty claim number to the repair
- Place a purchase order for genuine Snorkel replacement parts
- Snorkel to dispatch parts via the requested method (in line with the required response time)
- Confirmation that a qualified technician is available to replace the part and that this person has been accepted by Snorkel to carry out such work under the warranty of the machine. Failure to do this may nullify the warranty.

FREIGHT DAMAGE

If a machine is received in a damaged condition, then the damage must be noted on the bill of lading and/or delivery documents and if possible photographs taken, prior to signing acceptance of the consignment. The freight company must be contacted by the Distributor and a damage claim registered immediately.

THIS WARRANTY EXCLUDES AND SNORKEL DOES NOT WARRANT:

1. Engines, motors, tires and batteries are manufactured by suppliers to Snorkel, who furnish their own warranty. Snorkel will, however, to the extent permitted; pass through any such warranty protection to the Distributor/Customer.
2. Any Snorkel product which has been modified or altered outside Snorkel factory without Snorkel written approval, if such modification or alteration, in the sole judgment of Snorkel Engineering and/or Service Departments, adversely affects the stability, reliability or service life of the Snorkel product or any component thereof.



Product Warranty

3. Any Snorkel product which has been subject to misuse and abuse, improper maintenance or accident. "Misuse" includes but is not limited to operation beyond the factory-rated load capacity and speeds. "Improper maintenance" includes but is not limited to failure to follow the recommendations contained in the Snorkel Operator's and Repair Parts Manuals.
4. Normal wear of any Snorkel component part(s). Normal wear of component parts may vary with the type, application or type of environment in which the machine may be used; such as, but not limited to sandblasting applications.
5. Routine maintenance, routine maintenance items and minor adjustments are not covered by this warranty, including but not limited to hydraulic fluid, filters and lubrication, paint and decals.
6. Any Snorkel product that has come into direct contact with any chemical or abrasive material.
7. Incidental or consequential expenses, losses, or damages related to any part or equipment failure, including but not limited to freight cost to transport the machine to a repair facility, downtime of the machine, lost time for workers, lost orders, lost rental revenue, lost profits, expenses or increased cost. This warranty is expressly in lieu of all other warranties, representations or liabilities of Snorkel, either expressed or implied, unless otherwise amended in writing by Snorkel.
8. Snorkel Warranty policy does not cover any duties, taxes, environmental fees including without limitation, disposal or handling of tires, batteries and petrochemical items.
9. Item specifically excluded are, fuel injectors, motor brushes, glow plugs, contactor tips and springs, oil filters, lamp bulbs, lamp lenses, O-rings, coolants, lubricants and cleaning material.
10. Failure of replacement parts due to fault misdiagnosis or incorrect fitting by the Distributor/Customer.

SNORKEL MAKES NO WARRANTIES WHICH EXTEND BEYOND THE DESCRIPTION OF THIS LIMITED WARRANTY

SNORKEL MAKES NO IMPLIED WARRANTY OF MERCHANTABILITY OR FITNESS FOR A PARTICULAR PURPOSE AND DISCLAIMS ALL LIABILITY FOR INCIDENTAL OR CONSEQUENTIAL DAMAGES, INCLUDING BUT NOT LIMITED TO INJURY TO PERSONS OR PROPERTY.

The Customer shall make all warranty claims through Snorkel directly or an Authorised Distributor. If unable to contact the Distributor, contact the Snorkel Service Department for further assistance.



Product Warranty

APPEAL

The buyer may appeal in writing against a rejected or adjusted claim to Snorkel Warranty Department within a period of 21 days of receiving the rejection or adjustment notice. The appeal should be grounded on express reasons and supported by relevant evidence. Appeals received outside of this time limit will not be considered.

WARRANTY SCHEDULE

Limited Warranty Periods

Item	Warranty Period
New machine materials and workmanship	1 year parts replacement
Structural components (Chassis, Turntable, Booms, Scissors)	5 years parts replacement or repair
Parts held in a Distributor's stock	12 months from date of invoice
Parts sold (non warranty)	6 months from date of invoice
Batteries	6 months from date of invoice
Other specifically excluded parts: Fuel injectors Motor brushes Glow plugs Contactor tips and springs Oils Filters Lamp bulbs Lamp lenses O-rings Coolants Lubricants Cleaning materials	Not covered by Warranty

**Local Distributor / Lokaler Vertiebshändler / Distributeur local
El Distribuidor local / Il Distributore locale**

**EUROPE, MIDDLE EAST
AFRICA & ASIA**

PHONE: +44 (0) 845 1550 058
FAX: +44 (0) 845 1557 756

NORTH & SOUTH AMERICA

PHONE: +1 785 989 3000
TOLL FREE: +1 800 255 0317
FAX: +1 785 989 3070

AUSTRALIA

PHONE: +61 1300 700 450
FAX: +61 2 9609 3057

NEW ZEALAND

PHONE: +64 6 3689 168
FAX: +64 6 3689 164



www.snorkellifts.com